

Multivariable Hodge theoretical invariants of germs of plane curves. II

Pierrette Cassou-Noguès and Anatoly Libgober

Abstract. The paper describes several invariants of plane curve singularities in terms of the data of associated Newton trees. Newton trees of singularities are discussed in detail also. The invariants which we study include the constants and faces of quasi-adjunction, log-canonical walls and Arnold-Steenbrink spectrum. As one of the consequences of these calculations we show the failure of ACC for the set of constants of quasi-adjunction of all plane curve singularities which contains the set of log-canonical thresholds as a subset.

2010 Mathematics Subject Classification. Primary 11-XX; Secondary 14-XX.

Keywords. Plane curve singularities, multivariable Alexander polynomial, faces of quasi-adjunction, spectrum of singularity, Newton trees, log-canonical thresholds

1. Introduction

In the first part of this work, [6], we studied Hodge theoretical invariants of local systems of the complements to germs of plane curve singularities. These invariants, called the faces of quasi-adjunction, yield a refinement of the multivariable Alexander polynomial of a link of isolated singularity or, more precisely, the refinement of the *characteristic varieties* associated with the fundamental group of the complements to the links. They also provide (in the case of curves) a multivariable generalization of the spectrum of singularity due to Arnold and Steenbrink.

In the present paper we develop algorithmic methods for calculating these Hodge theoretical invariants in terms of power series which are the defining equations of the germs. Given such a power series we describe a decorated by integers graph with two types of 0-dimensional cells and two types of 1-dimensional cells (cf. below in this introduction). This graph is called *the Newton tree* (cf. sect.2.3). After dropping distinction between types of edges in the Newton tree one essentially obtains the splice diagram of Eisenbud and Neumann ([9]) for the link of the singularity of f . Newton trees earlier were used for the study of quasi-ordinary power series in [2] and [3], ideals in $\mathbb{C}[[x, y]]$ in [7] and plane algebraic curves in [5]. Here we also associate with a germ the toroidal (in the sense of [15]) pair (U_f, D) which provides a resolution *in the category of toroidal pairs* of the pair (B, C) , where C is the germ of plane curve and B is a small ball about the singular point of C . Our resolution can as well be viewed as a resolution in the category of orbifolds.

*First author is partially supported by the grants MTM2010-21740-C02-01 and MTM2010-21740-C02-02. The second author was supported by a grant from J.Simons Foundation.

Unlike previously used *smooth* resolutions (cf. references in [26]) use of toroidal resolutions allows to encode whole resolution process into the combinatorial data i.e. the Newton tree. Previous attempts to use mildly singular resolutions in this context were made in [22], [4], [11]. Use of such type of resolutions is also consistent with philosophy used in the minimal model program (cf. [13] and references there and [28]).

One of the main results in this paper describes the polytopes of quasi-adjunction in terms of Newton tree (cf. theorem 4.4). Among other things such description allows to get results on the structure of the polytopes of quasi-adjunction and make many explicit calculations. Since the log-canonical threshold is one of the constants of quasi-adjunction ¹, as a consequence we also obtain explicit description of the polytope which is the (multivariable) log-canonical threshold ² and also the part of the toroidal resolution U_f which determines it. Using the relation between the faces of quasi-adjunction and Bernstein ideals obtained in [6], here we obtain a polynomial (a product of linear forms) which divides all the polynomials in the Bernstein ideal associated with a multibranch singularity (cf. [6]).

Here is one of the consequences of calculations in this paper. In example 5.1 we consider a sequence of singularities such that the sequence of constants of quasi-adjunction (corresponding to $\phi = y^2$) is given by $\frac{13+6q}{18+8q}$ which is increasing sequence when $q \rightarrow \infty$. The sequence of log-canonical thresholds for this sequence of singularities is (decreasing) sequence $\frac{2+q}{4q}$. Recall that set of log-canonical thresholds of singularities contains only finite ascending sequences (cf. [25] for a much more general discussion).

Let us describe the content of the paper in more details. In the first section we recall the definition and construction of Newton trees of a germ f . The Newton tree is a tree (with additional structure), built from the Newton polygons that appear at each stage of the Newton algorithm. This additional structure consists with splitting 0-dimensional (resp. 1-dimensional) cells of the tree into two types called *vertices* and *arrows* (resp. *horizontal* and *vertical*). Each vertex in the Newton tree corresponds to a face of the Newton polygon of a polynomial appearing in a step of the Newton algorithm. It is decorated by integers extracted from the data obtained from the linear form vanishing on a face. The Newton tree determines the dual graph of the smooth resolution of the singularity of f obtained after resolving cyclic quotient singularities of our toroidal resolution. More precisely, we have a bijection between the vertices of the Newton tree and the exceptional divisors in the resolution which intersect other exceptional divisors at least three times (“rupture points” of the dual graph). One of the results in this section is that the Newton tree is sufficient to compute the polytopes of quasi-adjunction i.e. only the “rupture points” contribute to the calculation of the polytopes of quasi-adjunction (this was observe in [6] already). In the following section, we prove that this condition is also necessary, that means that all the vertices in the Newton tree contribute to a face of a polytope of quasi-adjunction. This is done using induction. Firstly

¹recall that these constants depend of a choice of germ $\phi \in \mathbb{C}_{0,0}^2$ and the log-canonical threshold corresponds to the choice $\phi = 1$ cf. [18].

²called here the log-canonical wall cf. Section 4.1 or [19].

we show that the intersections of the polytopes of quasi-adjunction of f_1, \dots, f_r with $\{s_1 = 1\}$ are the polytopes of quasi-adjunction of f_2, \dots, f_r . Then we prove the result for $r = 1$. In particular we retrieve the computation of M.Saito of the exponents between 0 and 1. Recall that the identification of the constants of quasi-adjunction and the spectrum was made in [20]. The result for r branches follows from the result for $r - 1$ branches except in the cases where some vertex doesn't appear in hyperplane $\{s_i = 1\}$ for any i . We have to work out these cases separately ($r = 2$ and $r = 3$).

The final section is devoted to the computation of the log canonical walls. Let f be a germ, we define the Newton nest of f , the following way. It is a set of vertices of the Newton tree, consisting in all vertices that correspond to faces of the Newton polygon of f in some system of coordinates. It is a connected set of vertices in the Newton tree. We show that the log canonical polytope is exactly given by the Newton nest of f . One can compare this with the result of J.Kollar showing the constant which is the log-canonical threshold of a germ depends only on the first characteristic pair (cf. [13]). The article ends with discussion of ACC conditions for constants and polytopes of quasi-adjunction and with additional explicit examples.

We would like to thank Manuel Gonzalez Villa for careful reading of the preliminary version of this paper and useful comments, which helped to correct exposition in section 3.2.

2. Newton trees

2.1. Newton polygons. For a subset $E \subset \mathbb{N}^2$, let $\Delta(E)$ denotes the convex hull of the set $E + \mathbb{R}_+^2 = \{a + b, a \in E, b \in \mathbb{R}_+^2\}$. The boundary of $\Delta(E)$ is a polygon with a finite number of vertices and edges. A subset $\Delta \subset \mathbb{R}^2$ is called a *Newton diagram* if there exists a set $E \subset \mathbb{N}^2$ such that $\Delta = \Delta(E)$. Let $E_0 = \{v_0, \dots, v_m\}$ be the set of vertices of Δ and let $v_i = (\alpha_i, \beta_i) \in \mathbb{N}^2$ with ordering such that $\alpha_{i-1} < \alpha_i, \beta_{i-1} > \beta_i$ for $i = 1, \dots, m$. For $i = 1, \dots, m$ we denote by $S_i = [v_{i-1}, v_i]$ and by l_{S_i} the line supporting the segment S_i . The union of compact edges of the boundary of a Newton diagram is called the *Newton polygon*. In above notation, it is the union of the edges S_i and denoted $\mathcal{N}(\Delta)$. The Newton polygon $\mathcal{N}(\Delta)$ is empty iff $\Delta = (\alpha_0, \beta_0) + \mathbb{R}_+^2$. The integer $h(\Delta) = \beta_0 - \beta_m$ is called the *height* of Δ .

Let

$$f(x, y) = \sum_{(\alpha, \beta) \in \mathbb{N}^2} c_{\alpha, \beta} x^\alpha y^\beta \in \mathbb{C}[[x, y]]$$

The support of f is

$$\text{Supp} f = \{(\alpha, \beta) \in \mathbb{N} \times \mathbb{N} \mid c_{\alpha, \beta} \neq 0\}.$$

We use $\Delta(f) = \Delta(\text{Supp} f)$ and $\mathcal{N}(f) = \mathcal{N}(\Delta(f))$. For a line l in \mathbb{R}^2 , the initial

part of f with respect to l is

$$\text{in}(f, l) = \sum_{(\alpha, \beta) \in l} c_{\alpha, \beta} x^\alpha y^\beta.$$

If the line l has equation $p\alpha + q\beta = N$, with $(p, q) \in (\mathbb{N}^*)^2$ and $\gcd(p, q) = 1$, then $\text{in}(f, l)$ is zero or a monomial or, if $l = l_S$ for some segment S of $\mathcal{N}(\Delta)$, of the form

$$\text{in}(f, l) = x^{a_l} y^{b_l} F_S(x^q, y^p),$$

where $(a_l, b_l) \in \mathbb{N}^2$ and

$$F_S(x, y) = c \prod_{1 \leq i \leq n} (y - \mu_i x)^{\nu_i},$$

with $c \in \mathbb{C}^*$, $n \in \mathbb{N}^*$, $\mu_i \in \mathbb{C}^*$ (all different) and $\nu_i \in \mathbb{N}^*$.

2.2. Newton algorithm.

DEFINITION 2.1. (*Newton maps*) Let $(p, q) \in \mathbb{N}^2$, $\gcd(p, q) = 1$ and $\mu \in \mathbb{C}^*$. Let $(p', q') \in \mathbb{N}^2$ such that $qq' - pp' = 1$. The map $\Pi_{(p, q, \mu)} : \mathbb{C}_{(x_1, y_1)}^2 \rightarrow \mathbb{C}_{(x, y)}^2$ given by $x = \mu^{q'} x_1^p, y = x_1^q (y_1 + \mu^{p'})$ is called *Newton map*.

We denote by $\Pi_{(p, q, \mu)}^*$ the induced homomorphism $\mathbb{C}[[x, y]] \rightarrow \mathbb{C}[[x_1, y_1]]$. The change $(p', q') \rightarrow (p' + iq', q' + ip)$ results in change of coordinates: $(x_1, y_1) \mapsto (\mu^i x_1, \mu^{-iq} y_1)$ and does not affect results.

In the sequel we will always assume that $p' < q$ and $q' < p$. This will make procedures canonical.

Lemma 2.2. [7] Let $f(x, y) \in \mathbb{C}[[x, y]]$, $f \neq 0$ and $\Pi_{(p, q, \mu)}^*(f)(x_1, y_1) = f_1(x_1, y_1) \in \mathbb{C}[[x_1, y_1]]$.

- (1) If there does not exist a face S of $\mathcal{N}(f)$ whose supporting line has equation $p\alpha + q\beta = k$ with $k \in \mathbb{N}$, then

$$f_1(x_1, y_1) = x_1^m u(x_1, y_1)$$

with $m \in \mathbb{N}$, $u(x_1, y_1) \in \mathbb{C}[[x_1, y_1]]$ and $u(0, 0) \neq 0$.

- (2) If there exists a face S of $\mathcal{N}(f)$ whose supporting line has equation $p\alpha + q\beta = k_0$ for some $k_0 \in \mathbb{N}$, and if $F_S(1, \mu) \neq 0$, then

$$f_1(x_1, y_1) = x_1^{k_0} u(x_1, y_1)$$

with $u(x_1, y_1) \in \mathbb{C}[[x_1, y_1]]$ and $u(0, 0) \neq 0$.

- (3) If there exists a face S of $\mathcal{N}(f)$ whose supporting line has equation $p\alpha + q\beta = k_0$ for some $k_0 \in \mathbb{N}$, and if $F_S(1, \mu) = 0$, then

$$f_1(x_1, y_1) = x_1^{k_0} g_1(x_1, y_1)$$

with $g_1(x_1, y_1) \in \mathbb{C}[[x_1, y_1]]$ and $g_1(0, 0) = 0, g_1(0, y_1) \neq 0$.

For the proof see [7].

From this lemma, we see that there are a finite number of (p, q, μ) such that $\Pi_{(p,q,\mu)}^*(f)$ is not a monomial times a unit in $\mathbb{C}[[x_1, y_1]]$. These triples are given by the equations of the faces of the Newton polygon and the roots of the corresponding face polynomials.

REMARK 2.3. *In the first and second case of Lemma 2.2, the Newton polygon of f_1 is empty. In the third case, the height of the Newton diagram of f_1 is less than or equal to the multiplicity of μ as root of $F_S(1, X)$.*

We say that $f \in \mathbb{C}[[x, y]]$ is in *good coordinates* if

- (1) $\beta_m \neq 0$ or
- (2) if $\beta_m = 0$ and
 - (a) either l_{S_m} has equation $p\alpha + q\beta = N$ with $p \neq 1$ or
 - (b) if $p = 1$, and $m \geq 1$ then F_{S_m} has at least two factors,
 - (c) if $p = 1$ and $m = 1$ F_{S_m} is not of the form

$$F_{S_m} = c(y - \mu_1 x)^{\nu_1} (y - \mu_2 x)^{\nu_2}$$

Lemma 2.4. *If $f \in \mathbb{C}[[x, y]]$ is not in good coordinates, there exist changes of variables in $\mathbb{C}[[x, y]]$ in which it is in good coordinates.*

The proof can be found in [16]. One has to take in account that our definition of good coordinates corresponds to their definition of quasi-good coordinates. The changes of coordinates we use to put f in good coordinates are $x = x, y = y + h(x)$ with $h \in \mathbb{C}[[x]]$.

We say that $f \in \mathbb{C}[[x, y]]$ is in *very good coordinates* if it is in good coordinates and

- (1) $\alpha_0 \neq 0$ or
- (2) if $\alpha_0 = 0$ and
 - (a) either l_{S_1} has equation $p\alpha + q\beta = N$ with $p \neq 1$ or
 - (b) if $p = 1$ and $m \geq 1$ then F_{S_1} has at least two factors.

Let $f \in \mathbb{C}[[x, y]]$ in very good coordinates. Let $\Pi = \Pi_{(p,q,\mu)}$ be a Newton map. We denote by f_Π the result of $\Pi^*(f)$ after a change of variables so that f_Π is in good coordinates. Let $\Sigma_n = (\Pi_1, \dots, \Pi_n)$ where Π_i is a Newton map for all i , we define f_{Σ_n} by induction: $f_{\Sigma_1} = f_{\Pi_1}$, $f_{\Sigma_i} = (f_{\Sigma_{i-1}})_{\Pi_i}$.

Theorem 2.5. *Let $f(x, y) \in \mathbb{C}[[x, y]]$, there exists an integer n_0 such that, for any sequence $\Sigma_n = (\Pi_1, \dots, \Pi_n)$ where Π_i is a Newton map for all i , of length at least n_0 , f_{Σ_n} is a monomial up to a unit.*

Proof. From Lemma 1.1, we first observe that the number of Newton maps Π , such that f_Π is not a monomial times a unit is finite, bounded by the sum on all faces S of the number of roots of F_S . What we have to show is that the number of successive Newton maps we have to perform so that f_Σ is a monomial up to a unit, is also finite.

We start with f in very good coordinates. In this system of coordinates, we denote by h the height of $\Delta(f)$. We argue by induction on h . If $h = 0$, then f is a monomial up to a unit, and $n = 0$. Consider the case where $h > 0$. In that case, $\mathcal{N}(f)$ is not empty. Choose a face of $\mathcal{N}(f)$, S , and a root of F_S with multiplicity ν . Let $\alpha p + \beta q = N$ be the equation of the supporting line of S . Then $f_1(x_1, y_1) = x_1^\nu g_1(x_1, y_1) \in \mathbb{C}[[x_1, y_1]]$ and the height of $\Delta(f_1)$ is $\nu < h$ since f is in good coordinates. □

If f is in very good coordinates, we define the *length* of the Newton algorithm \mathcal{A} applied to f , $d(f, \mathcal{A})$ by induction ³. If f is a monomial up to a unit, then $d(f, \mathcal{A}) = 0$. Otherwise $d(f, \mathcal{A}) = \max d(f_\Pi) + 1$ where the maximum is taken over all faces S of the Newton polygon and all roots of F_S . Note that the definition of the length depends on the choice of good coordinates at each step of the Newton algorithm.

2.3. Newton trees. Given $f \in \mathbb{C}[[x, y]]$ in very good coordinates, the Newton algorithm consists in applying successive Newton maps attached to successive Newton polygons and changes of variables until the result is a monomial times a unit.

Newton trees are trees that encode the Newton algorithm. They are build by induction, and defined via gluing certain graphs associated to a Newton diagram. More specifically:

DEFINITION 2.6. *An abstract Newton tree is a graph with no loops with two types of 0-dimensional cells, called vertices and arrows and two types of 1-dimensional cells called horizontal and vertical edges.*

Decoration of an abstract Newton tree is assignment of an integer to a vertex or arrow (represented below in parenthesis) and assignment an integer to each end of an edge. Below the integers assigned to unmarked ends are considered to be equal to 1.

All abstract Newton trees have one marked arrow called upper arrow.

2.3.1. Graph associated to a Newton diagram.

DEFINITION 2.7. *1. Graph associated to a Newton diagram is an abstract Newton tree with vertices a_1, a_2, \dots, a_m which are in (ordered) 1-1-correspondence with compact 1-dimensional faces S_i of the boundary of Newton diagram, arrows a_0, a_{m+1} corresponding to the non-compact faces of the boundary of Newton diagram and $m + 1$ vertical edges connecting a_i and a_{i+1} for $i = 0, \dots, m$. Increase of subscript*

³sometimes the term “depth” was used earlier

corresponds to the downward moving on the graph. The arrow a_0 is called the upper arrow.

If $\Delta = (\alpha_0, \beta_0) + \mathbb{R}_+^2$ then the graph of Δ is defined as follows: the graph has no vertices and it has one edge incident to two arrows and the edge is vertical. The upper arrow is defined as the arrow decorated by (α_0) and the arrow at the bottom is decorated by (β_0) .

Now let us describe the decoration of the graph of a Newton diagram. If the non compact faces of the Newton diagram are $\alpha = \alpha_0$ and $\beta = \beta_m$ then the upper arrow is decorated by (α_0) and the arrow at the bottom is decorated by β_m . The edges incident to the arrows are decorated with 1 near the arrows. The extremities of the edges are decorated the following way: A vertex corresponds to a face S whose supporting line has equation $p\alpha + q\beta = N$. We decorate the extremity of the edge above the vertex by q , and the extremity of the edge under the vertex by p . We decorate the vertex by (N) .

Note that one can recover the whole Newton polygon from the graph since we can read the equations of the supporting lines of the faces on the graph i.e. the data given by the graph and by the Newton diagram are identical.

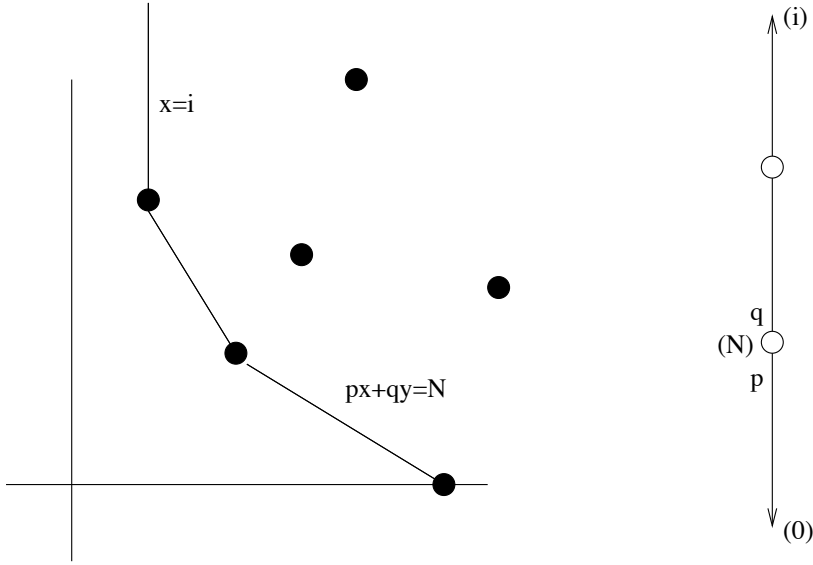

Figure 1.

2.3.2.]] *Newton tree of $f \in \mathbb{C}[[x, y]]$.*

The Newton tree of f is defined by induction on the length. Suppose that f has length 0. Then f is a monomial times a unit and we define its Newton tree as

the graph of its Newton diagram (cf. def. 2.7).

Assume that we have constructed the Newton tree for all f of length less than or equal to $n - 1$. Let $f \in \mathbb{C}[[x, y]]$ in very good coordinates and having length n . We define the Newton tree of f in terms of the following data. On one hand the definition 2.7 provides the graph associated to its Newton diagram. On the other hand, for each edge of the Newton polygon and each root of the polynomial corresponding to this edge via the Newton map Π and subsequent change to good coordinates we obtain the polynomial f_Π of length at most $n - 1$. The assumption of induction yields the Newton tree of f_Π (for each edge of the Newton polygon of f).

DEFINITION 2.8. *The Newton tree of f is the tree obtained from the above data as follows. Delete the upper arrow of the Newton tree of each f_Π (recall that each Π corresponds to a vertex of the graph of Newton diagram of f) and glue the edge which was incident to that arrow to the corresponding vertex on the graph of the Newton diagram of f for all Π . Moreover, the edges that are glued are renamed to horizontal edges. All other edges of the graph of the Newton diagram of f and the Newton trees of f_Π retain the labels which they had as edges of the trees. The upper arrow of the graph of the Newton diagram of f is declared the upper arrow of the Newton tree of f .*

To sum up, in this construction the vertices on graph of f are all incident to vertical edges and correspond to the faces on the Newton polygon of some f_Π . The horizontal edges correspond to the successive Newton maps used to construct polynomials f_Π .

Decorations of the Newton tree of f are defined in terms of decorations of the graph of Newton diagram of f and the decorations of f_Π as follows.

DEFINITION 2.9. *Let v be a vertex of a Newton tree. If v corresponds to a face of the Newton polygon of f , we say that v has no preceding vertex and we define $\mathcal{S}(v) = \{v\}$. Let v be a vertex on a Newton tree. It is on the Newton polygon of f_Σ . The Newton tree of f_Σ has been glued on a vertex v_1 which is called the preceding vertex of v . If v_1 does not correspond to a face of the Newton polygon of f , we can consider its preceding vertex v_2 . Then we can define $\mathcal{S}(v) = \{v_i, \dots, v_2, v_1, v\}$, where v_i has no preceding vertex and v_j is the preceding vertex of v_{j-1} for $2 \leq j \leq i$.*

The final Newton tree is decorated the following way. The decorations of the arrows and vertices are not changed. The decorations of the edges are changed. Let v be a vertex on the Newton tree. If $\mathcal{S}(v) = \{v\}$ then the decorations near v are not changed. If $\mathcal{S}(v) = \{v_i, \dots, v_2, v_1, v\}$ and if the decoration near v on the Newton tree such that $\mathcal{S}(v) = \{v_{i-1}, \dots, v_2, v_1, v\}$ (that is on the Newton tree which is glued at v_i), are (m, p) , after the gluing, the decorations near v are $(m + p_i q_i p_{i-1}^2 \cdots p_1^2 p, p)$.

As an example the following is the Newton tree of $f(x, y) = (x^2 - y^3)^2(x^3 - y^2)^2 + x^6 y^3 + x^5 y^5 + x^4 y^7$

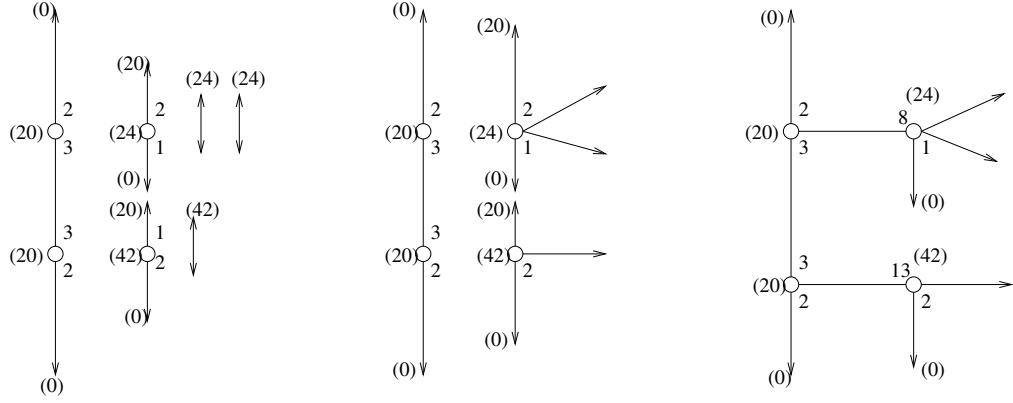

Figure 2.

If we add an arrow to a vertex of a Newton tree, this arrow defines a germ of curve. This germ of curve is called a *curvette* of the vertex. If v is the vertex, we denote by \mathcal{C}_v its curvette. It is called a virtual component in [9].

Note that on the edges arising for a vertex there are at most two decorations on the ends near the vertex which are different from 1. We call them *nearby decorations* of the vertex.

2.4. Change of variables. Newton trees are constructed using a very good system of coordinates. But very good systems of coordinates are not unique. We want to study the Newton trees in different systems of very good coordinates.

Consider a system of very good coordinates for f . Consider the Newton polygon of f in this system of coordinates.

If there is no face of the Newton polygon with equation $p\alpha + q\beta = N$ with p or q equal to 1, then there is no other system of good coordinates.

If there is a face of the Newton polygon with equation $p\alpha + q\beta = N$ with p or q equal to 1, assume $p = 1$. Let

$$cx^{a_S}y^{b_S} \prod_{i=1}^{k_S} (y - \mu_i x^q)^{\nu_i}$$

be the face polynomial. Since we are in very good coordinates, we have $b_S \neq 0$ or if $q \neq 1$, $k_S > 1$, and if $q = 1$, $k_S > 2$.

We make the change of variables $x = x, y = y + ax^q$.

The faces above S do not change neither their face polynomial. The face S has the same supporting line but its face polynomial is now

$$cx^{a_S}(y - ax^q)^{b_S} \prod_{i=1}^{k_S} (y - (\mu_i - a)x^q)^{\nu_i}$$

If $a = \mu_i$, for some i , the face doesn't hit the x -axis. If $a \neq \mu_i$ for all i , the face hits the x -axis, but anyway we are still in very good coordinates.

We want to compare the Newton trees in these two systems of coordinates.

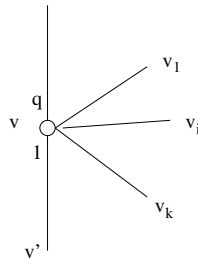

Figure 3.

We consider the vertex v which represents the face S . There are k_S horizontal edges starting from v corresponding to each root μ of the face polynomial. There is a vertical edge decorated with 1 near v under v and a vertical edge decorated with q above v . All the edges can be ended by vertices or arrows. We denote these ends by v_i for the horizontal edges and v' for the vertical edge pointing downward. We make the change of variables $x = x, y = y + ax^q$.

- (1) If $a \neq \mu_i$ for all i . Then the new Newton tree is in Figure 4. We have $k_S + 1$ horizontal edges, one for each of the roots μ_i and one for a . We proved in [8] that in this case, we cut out the Newton tree in two pieces on the vertical edge under v . We have \mathcal{T}_a which contains v and \mathcal{T}_u which contains the vertical edge ending with v' . We stick back \mathcal{T}_u on v making the vertical edge ending with v' , horizontal and we add a vertical edge decorated with 1 ending with an arrow decorated with (0) (On Figure 6, we start with Newton tree 2 or 3 and get Newton tree 1).

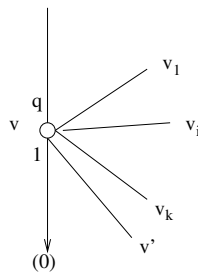

Figure 4.

- (2) If $a = \mu_i$, We cut the Newton tree in 3 pieces. We cut the vertical edge ending with v' , we cut the horizontal edge ending with v_i . We have the piece containing v , the piece containing v' and the piece containing v_i . We stick the piece containing v_i making the edge ending with v_i vertical. We stick the piece containing v' on v making the edge containing v' horizontal. We call this operation exchange of vertical edge (On Figure 6, we exchange Newton trees 2 and 3).

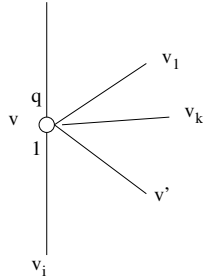

Figure 5.

Note that some faces may appear on the Newton polygon in some system of very good coordinates, but that there is not always a system of coordinates such that they all appear at the same time.

EXAMPLE 2.10. :

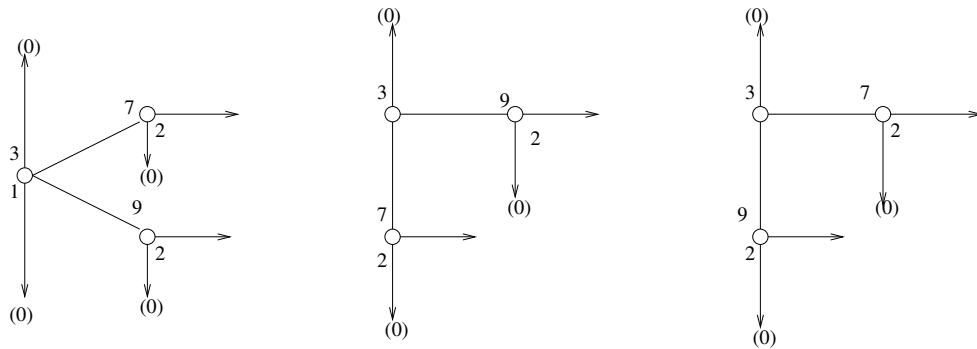

Figure 6.

In this example, the 3 vertices can correspond to faces of a Newton polygon in some system of coordinates, but at most two of them appear in the same system of coordinates.

DEFINITION 2.11. *We say that two Newton trees are equivalent if they differ by exchanging vertical and horizontal edges, and eventually deleting horizontal edges ending with arrows decorated with (0).*

We can chose a canonical representant of an equivalent class of Newton tree the following way: At each vertex the only possible edge decorated with 1 near the vertex which is not horizontal ends with an arrow decorated with (0).

In Figure 6, the three Newton trees are equivalent. The canonical representant of the class is the first one.

Equivalent Newton trees represent f in different systems of good coordinates.

Proposition 2.12. *Newton trees of $f \in \mathbb{C}[[x, y]]$ in different systems of good coordinates have the same number of vertices. This number is called the Newton complexity of f .*

2.5. Combinatorial properties of Newton trees. .

Proposition 2.13. *If v_0 is the preceding vertex of v with nearby decorations respectively (q_0, p_0) and (q, p) , we have*

$$q = p_0 q_0 p + \tilde{m}.$$

where (\tilde{m}, p) are the nearby decorations of v on the Newton tree where $\mathcal{S}(v) = \{v\}$.

Proof. See [7]. □

DEFINITION 2.14. *Consider a path on a Newton tree. We say that a number is adjacent to this path if it is not on the path and is a nearby decoration of a vertex on the path. If the path contains an arrow, the decoration of the arrow is a number adjacent to the path.*

DEFINITION 2.15. *Consider an edge on a Newton tree, its edge determinant is the difference between the product of the numbers on the edge and the product of the numbers adjacent to the edge when the edge is incident to two vertices. If the edge is incident to one arrow, its edge determinant is the product of the decorations on the edge.*

Corollary 2.16. (1) *In the process of gluing, the edge determinants remain constant.*

(2) *All edges determinants are strictly positive integers.*

Proof. This is a consequence of the previous proposition. □

Proposition 2.17. *The decoration (N) of a vertex v on a Newton tree is the sum over all the arrows \mathcal{F} of the tree, of the products of the numbers adjacent to the paths $[v, \mathcal{F}]$.*

For a proof see [7], Proposition 3.3.

REMARK 2.18. *From this proposition we see that when the tree is constructed, the decorations of the vertices are not needed any more because we can compute them from the decorations of the edges. But, anyway, we have to keep in mind that we know them from the beginning.*

2.6. Computation of the intersection multiplicity using Newton trees.

Proposition 2.19. *The intersection multiplicity of two branches f and g is equal to the product of all the numbers adjacent to the path going from the arrow representing f to the arrow representing g on any Newton tree where f and g are represented.*

Corollary 2.20. *The decoration N_v of a vertex v of a Newton tree of a germ f is equal to the intersection multiplicity of the curvette C_v and f .*

See [7] Proposition 5.3.

Given a Newton tree, the arrows decorated with positive multiplicities correspond to branches with the same multiplicity. Along horizontal paths from the first vertical line to any arrow one can compute the Puiseux pairs of the branch. One can also compute the intersection multiplicity of any two branches. Then the data of the Newton tree of f give the topological type of f . Given a decorated tree satisfying the condition of positivity of edge determinants there exist germs f with this Newton tree.

The Newton tree of f , without specification of edges as horizontal or vertical coincide with the splice diagram of the link of the singularity of f at the origin defined by Eisenbud and Neumann [9].

3. Newton space

In this section for a series $f \in \mathbb{C}[[x, y]]$, we describe a morphism $\pi_f : U_f \rightarrow \mathbb{C}^2$, where U_f is a toroidal variety with quotient singularities, π_f is birational and has the property that the proper preimage of $f = 0$ does not intersect the singular locus of U_f and is transversal to the exceptional set of π_f . Its construction is much simpler than the construction of log-resolution of pair (\mathbb{C}^2, C) where C is the zero set of f . We show that U_f comes with the atlas of affine surfaces which are global quotients by cyclic group and hence provides resolution of pair (\mathbb{C}^2, C) in the category of orbifolds.

3.1. Factorization of monomial maps.. Let N be a free abelian group of rank two with fixed basis $\{E_1, E_2\}$. We use the latter to identify N with \mathbb{Z}^2 . Elements of N will be represented as column vectors e.g. E_1 and E_2 correspond to ${}^t(0, 1)$ and ${}^t(1, 0)$ respectively. Let N^+ be the subset of vectors with positive coordinates.

3.1.1. The variety U_σ . Let $\{P_1, P_2\}$ be a pair of primitive vectors in N^+ . Let $P_i = {}^t(p_i, q_i)$ and assume that $\Delta = \det(P_1, P_2) = p_2q_1 - p_1q_2 > 0$. Let

$$\sigma = \text{cone}(P_1, P_2) = \{tP_1 + sP_2, t, s \geq 0\}$$

The toric surface corresponding to this cone will be denoted U_σ (cf. [10], p. 4). It is biregular to a quotient of \mathbb{C}^2 by a cyclic group. Let us recall the description of the order of this cyclic group and its action yielding U_σ .

Let ${}^t(p'_1, q'_1)$ be the unique vector such that $p'_1q_1 - p_1q'_1 = 1$ and $0 \leq p_2q'_1 - q_2p'_1 < p_2q_1 - p_1q_2$. The relation

$${}^t(p_2, q_2) = c^t(p_1, q_1) + d^t(p'_1 - p_1, q'_1 - q_1)$$

yields two integers c, d and we have

$$d = \Delta, \quad c = \Delta - (p_2q'_1 - q_2p'_1) > 0, \quad \gcd(c, d) = 1$$

Let G_d be the group of d -roots of unity. Then the variety U_σ can be parametrized via

$$\begin{array}{ccccc} \mathbb{C}^2 & \longrightarrow & \mathbb{C}^2/G_d & \simeq & U_\sigma \\ (t_1, t_2) & \mapsto & (\zeta_d^{-c}t_1, \zeta_d t_2) & \mapsto & (u_1 = t_1 t_2^c, u_2 = t_1^d, u_3 = t_2^d) \end{array}$$

We can also define the variety U_σ the following way. Let ${}^t(p''_2, q''_2)$ be the unique vector such that $p_2q''_2 - p''_2q_2 = 1$ and $p''_2q_1 - q''_2p_1 < p_2q_1 - q_2p_1$. We can write

$${}^t(p_1, q_1) = \tilde{c}^t(p_2, q_2) + d^t(p''_2 - p_2, q''_2 - q_2),$$

where $\tilde{c} = \Delta - (p''_2q_1 - q''_2p_1) > 0$.

$$\begin{array}{ccccc} \mathbb{C}^2 & \longrightarrow & \mathbb{C}^2/G_d & \simeq & U_\sigma \\ (t_1, t_2) & \mapsto & (\zeta_d t_1, \zeta_d^{-\tilde{c}} t_2) & \mapsto & (\tilde{u}_1 = t_2^d, \tilde{u}_2 = t_1^{\tilde{c}} t_2, \tilde{u}_3 = t_1^d) \end{array}$$

Note that $c\tilde{c}$ is congruent to 1 modulo d .

DEFINITION 3.1. Let $\Pi_\sigma : \mathbb{C}^2 \rightarrow \mathbb{C}^2$ be given by:

$$(t_1, t_2) \mapsto (x = t_1^{p_1} t_2^{p_2}, y = t_1^{q_1} t_2^{q_2})$$

The maps κ_σ and π_σ appearing in the diagram:

$$\mathbb{C}^2 \xrightarrow{\kappa_\sigma} U_\sigma \xrightarrow{\pi_\sigma} \mathbb{C}^2$$

will be called the (toric) uniformization and the (toric) blow up respectively.

Lemma 3.2. The morphism $\pi_\sigma : U_\sigma \rightarrow \mathbb{C}^2$ is birational.

Proof. Let (x, y) be the coordinates on \mathbb{C}^2 . We have

$$u_1 = \frac{y^{p'_1 - p_1}}{x^{q'_1 - q_1}}, \quad u_2 = \frac{y^{p_2}}{x^{q_2}}, \quad u_3 = \frac{x^{q_1}}{y^{p_1}}$$

□

The lines $D_3 := \{u_1 = 0, u_2 = 0\}$ and $D_2 := \{u_1 = 0, u_3 = 0\}$ are contained in U_σ . The line D_3 contracts by π_σ on the origin in \mathbb{C}^2 if and only if p_1 is different from 0, and the line D_2 contracts by π_σ on the origin in \mathbb{C}^2 if and only if q_2 is different from 0. If $d > 1$ the origin in \mathbb{C}^3 is a singular point in U_σ with a quotient singularity.

3.1.2. Gluing U_σ and $U_{\sigma'}$. Let σ be the cone $\text{cone}(P_1, P_2)$ as before and σ' be the cone $\text{cone}(P_2, P_3)$ with $P_3 = {}^t(p_3, q_3)$ and $p_3q_2 - p_2q_3 > 0$.

We have

$$\begin{array}{ccc} \mathbb{C}^2 & \longrightarrow & U_\sigma & \longrightarrow & \mathbb{C}^2 \\ (t_1, t_2) & \longmapsto & (x = t_1^{p_1} t_2^{p_2}, y = t_1^{q_1} t_2^{q_2}) & & \\ \mathbb{C}^2 & \longrightarrow & U_{\sigma'} & \longrightarrow & \mathbb{C}^2 \\ (t_1, t_2) & \longmapsto & (x = t_1^{p_2} t_2^{p_3}, y = t_1^{q_2} t_2^{q_3}) & & \end{array}$$

We glue U_σ and $U_{\sigma'}$ along D_2 on U_σ and D'_3 on $U_{\sigma'}$. We have $u_2 = \frac{y^{p_2}}{x^{q_2}}$ and $u'_3 = \frac{x^{q_2}}{y^{p_2}}$. Then let A be a point on D_2 . Its coordinates are $(0, \xi, 0)$ on U_σ , $(0, 0, \xi)$ on $U_{\sigma'}$ and $\pi_\sigma(A) = \pi_{\sigma'}(A)$.

3.1.3. Decomposition of σ into $\sigma_1 \cup \sigma'_1$. Let $P_3 = {}^t(p_3, q_3)$ be such that $p_3q_1 - q_3p_1 > 0$ and $p_2q_3 - p_3q_2 > 0$. Denote by σ_1 the cone $\text{cone}(P_1, P_3)$. Let (u_1, u_2, u_3) the coordinates in \mathbb{C}^3 such that $U_\sigma \subset \mathbb{C}^3_{u_1, u_2, u_3}$ and (u_1^1, u_2^1, u_3^1) the coordinates in \mathbb{C}^3 such that $U_{\sigma_1} \subset \mathbb{C}^3_{u_1^1, u_2^1, u_3^1}$. Let (c_1, d_1) be defined as before for the cone σ_1 .

We have by π_σ^{-1}

$$\begin{array}{ccc} \mathbb{C}^2 & \longrightarrow & U_\sigma \\ (x, y) & \longmapsto & (u_1 = \frac{y^{p_1 - p_1}}{x^{q_1 - q_1}}, u_2 = \frac{y^{p_2}}{x^{q_2}}, u_3 = \frac{x^{q_1}}{y^{p_1}}) \end{array}$$

The morphism π_{σ_1} is the factorization to U_{σ_1} of the morphism

$$\begin{array}{ccc} \mathbb{C}^2 & \longrightarrow & U_{\sigma_1} & \longrightarrow & \mathbb{C}^2 \\ (v_1, v_2) & \longmapsto & (x = v_1^{p_1} v_2^{p_3}, y = v_1^{q_1} v_2^{q_3}) & & \end{array}$$

After a short computation, we deduce

$$u_1 = v_1 v_2^{c_1} = u_1^1, u_2 = v_1^{q_1 p_2 - q_2 p_1} v_2^{q_3 p_2 - p_3 q_2}, u_3 = v_2^{d_1} = u_3^1$$

Then we have a morphism from \mathbb{C}^2 to U_σ which factorizes to U_{σ_1} . Denote by $\pi_{\sigma_1, \sigma}$ this factorization. We have

$$\pi_{\sigma_1} = \pi_\sigma \circ \pi_{\sigma_1, \sigma}$$

The morphism $\pi_{\sigma_1, \sigma}$ is the identity from D_3^1 on D_3 and the line D_2^1 contracts to the singular point in U_σ .

We can also consider the cone σ'_1 , $\text{cone}(P_3, P_2)$. Using the second parametrization of U_σ we can define the same way as before, a morphism $\pi_{\sigma'_1, \sigma}$. We have

$$\pi_{\sigma'_1} = \pi_\sigma \circ \pi_{\sigma'_1, \sigma}$$

Now the morphism $\pi_{\sigma'_1, \sigma}$ is the identity from $D_2^{1'}$ on D_2 and $D_3^{1'}$ contracts on the singularity of U_σ . We can glue U_{σ_1} and $U_{\sigma'_1}$ as before and we have a morphism from this new variety to U_σ .

3.1.4. Newton maps. Let $\{P_1, \dots, P_m\}$ be given positive primitive integral vectors in N^+ . We denote by $P_0 = E_1$ and $P_{m+1} = E_2$.

To begin, we consider the cone $\sigma_m = \text{cone}(P_0, P_m)$ and the cone $\sigma'_m = \text{cone}(P_m, P_{m+1})$. We consider the variety U_{σ_m} and the morphism π_{σ_m} which is the factorization of the Newton map

$$\begin{array}{ccc} \mathbb{C}^2 & \longrightarrow & U_{\sigma_m} & \longrightarrow & \mathbb{C}^2 \\ (t_1, t_2) & & \mapsto & & (x = t_2^{p_m}, y = t_1 t_2^{q_m}) \end{array}$$

We glue U_{σ_m} and $U_{\sigma'_m}$ along D_2^m and $D_3^{m'}$. We get a variety U_m and a birational morphism π_m which is π_{σ_m} on the chart U_{σ_m} . The line $D_2^m = D_3^{m'}$ contracts on the origin of \mathbb{C}^2 . The lines D_3^m and $D_2^{m'}$ are not contracted. There is a singularity at the origin of U_{σ_m} (resp. $U_{\sigma'_m}$) if and only if the cone σ_m (resp. σ'_m) is not regular.

Next we consider the subdivision of σ_m in two cones $\sigma_{m-1} = \text{cone}(P_0, P_{m-1})$ and the cone $\sigma'_{m-1} = \text{cone}(P_{m-1}, P_m)$. We consider the variety $U_{\sigma_{m-1}}$ and the map $\pi_{\sigma_{m-1}}$ which is the factorization of the Newton map

$$\begin{array}{ccc} \mathbb{C}^2 & \longrightarrow & U_{\sigma_{m-1}} & \longrightarrow & \mathbb{C}^2 \\ (t_1, t_2) & & \mapsto & & (x = t_2^{p_{m-1}}, y = t_1 t_2^{q_{m-1}}) \end{array}$$

This map factorizes through U_{σ_m} . When we glue $U_{\sigma_{m-1}}$ and $U_{\sigma'_{m-1}}$ we have a birational morphism $\pi_{m,m-1}$ from this variety on U_{σ_m} which is the identity on D_2^{m-1} . We glue $U_{\sigma'_m}$ along D_3^m and extend $\pi_{m,m-1}$ by the identity in this chart. We obtain a variety U_{m-1} and a birational map $\pi_{m,m-1}$ from U_{m-1} to U_m . On the chart $U_{\sigma_{m-1}}$ we have

$$\pi_{\sigma_m} \circ \pi_{m,m-1} = \pi_{\sigma_{m-1}}$$

Finally we get a toric variety U associated to the subdivision and a birational morphism π from U to \mathbb{C}^2 . Along one exceptional divisor E , the morphism π is the Newton map π_{σ_i} where $E = D_2^i$ on U_{σ_i} . The variety U is smooth if and only if the subdivision is regular.

We denote $\pi^{-1}(0) = \cup_{i=1}^m E(P_i)$ where $E(P_1) = D_2^1, E(P_2) = D_2^1 \cdots E(P_m) = D_2^{m-1}$.

The configuration graph of the exceptional divisor of $\pi : U \rightarrow \mathbb{C}^2$ is a linear graph with m vertices. We will represent this graph on a vertical line. We represent the divisors $E(P_1), \dots, E(P_m)$ from top to bottom. We connect the vertices by a segment since the divisors intersect. We add an edge at the top and at the bottom with arrows since they represent E_1 and E_2 but not exceptional divisors. To keep the information on the subdivision, we decorate the vertex corresponding to $E(P_i)$ with q_i on the edge above the vertex and p_i on the edge under the vertex. Usually we don't write the decorations for E_1 and E_2 , but they appear in the computations as $(0, 1)$ and $(1, 0)$. The number d attached to a cone is computed

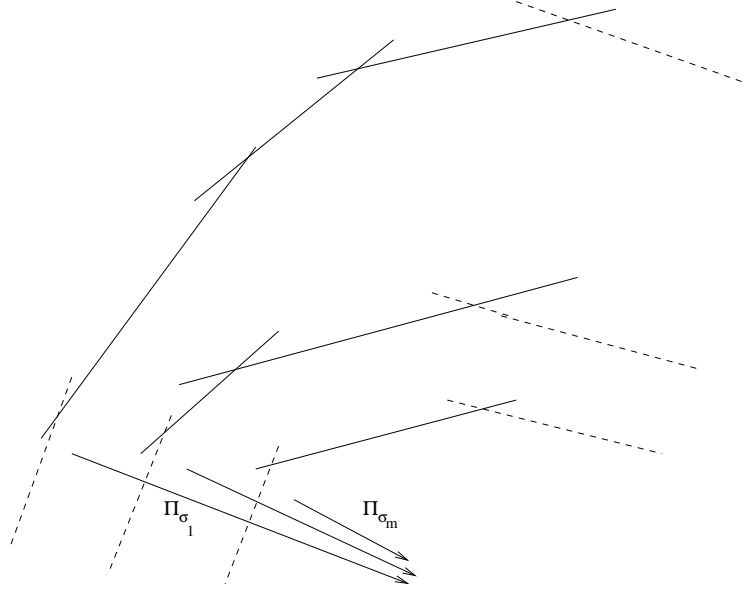

Figure 7.

as the edge determinant of the corresponding edge, ie. the product of the numbers on the edge minus the product of the numbers adjacent to the edge.

Each edge of the dual graph corresponds to a quotient singularity, of type the determinant of the edge. For the top and bottom edge it is q_1 and p_m respectively.

EXAMPLE 3.3. We start with a Newton polygon with two faces with equations $3\alpha + 2\beta = 12$ and $3\alpha + 4\beta = 21$. We obtain the set of primitive vectors $\{P_1 = {}^t(3, 4), P_2 = {}^t(3, 2)\}$. We set as before $P_0 = (0, 1)$ and $P_3 = (1, 0)$. We consider the cones $\sigma_2 = \text{cone}(P_0, P_2)$ and $\sigma'_2 = \text{cone}(P_2, P_3)$. We have a toric variety U_2 which is the gluing of U_{σ_2} and $U_{\sigma'_2}$ and a birational map π_2 from U_2 to \mathbb{C}^2 with one exceptional divisor E_2 and $\pi_2|_{E_2}$ is the restriction of the morphism

$$\begin{array}{ccc} \mathbb{C}^2 & \longrightarrow & U_{\sigma_2} & \longrightarrow & \mathbb{C}^2 \\ (t_1, t_2) & & \mapsto & & (x = t_2^3, y = t_1 t_2^2) \end{array}$$

Now we split the cone σ_2 in $\sigma_1 = \text{cone}(P_0, P_1)$ and $\sigma'_1 = \text{cone}(P_1, P_2)$. We have a toric variety U which is the gluing of U_{σ_1} , $U_{\sigma'_1}$ and $U_{\sigma'_2}$ and a birational map π from U to \mathbb{C}^2 with two exceptional divisors E_1 and E_2 intersecting each other. The restriction of π to E_2 is the restriction of π_2 to E_2 . The restriction of π to E_1 is the restriction to E_1 of the morphism

$$\begin{array}{ccc} \mathbb{C}^2 & \longrightarrow & U_{\sigma_1} & \longrightarrow & \mathbb{C}^2 \\ (t_1, t_2) & & \mapsto & & (x = t_2^3, y = t_1 t_2^4) \end{array}$$

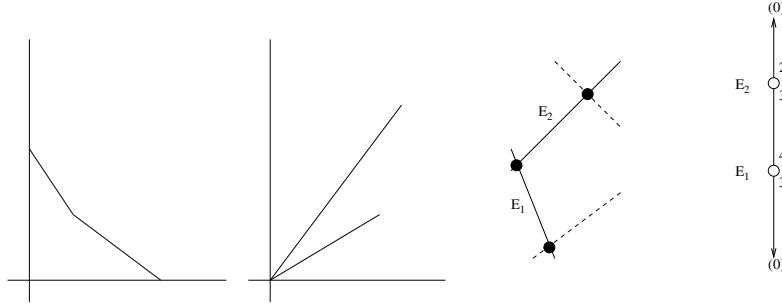

Figure 8.

The toric variety U is singular with 3 quotient singularities.

We represent the two exceptional divisors by two vertices with an edge connecting them since they intersect. We represent the lines D_2^1 on U_{σ_1} and $D_3^{\prime 2}$ on U_{σ_2} by an arrow decorated with (0) . They are not exceptional divisors.

3.2. Resolution of germs of plane curves.

Let us begin by an example:

EXAMPLE 3.4. Consider the germ

$$f(x, y) = x^3 - y^2$$

The Newton polygon of f has one face with equation $2\alpha + 3\beta = 6$. We consider the two cones $\sigma = \text{cone}({}^t(0, 1), {}^t(2, 3))$ and $\sigma' = \text{cone}({}^t(2, 3), {}^t(1, 0))$. The gluing of U_σ and $U_{\sigma'}$ gives a toric variety U and a birational morphism from U to \mathbb{C}^2 . There is one exceptional divisor E_1 and the restriction of π on E_1 is given by the restriction of the morphism

$$\begin{array}{ccc} \mathbb{C}^2 & \longrightarrow & U_\sigma & \longrightarrow & \mathbb{C}^2 \\ (t_1, t_2) & & \mapsto & & (x = t_2^2, y = t_1 t_2^3) \end{array}$$

We have

$$f(t_2^2, t_1 t_2^3) = t_2^6(1 - t_1^2)$$

which means

$$\pi^* f = \tilde{C} + 6E(P_1)$$

where \tilde{C} is the proper transform which intersects transversally the divisor E_1 in one point and is smooth.

The Newton tree associated to this germ is given on Figure 9.

The vertex represents the divisor E_1 . It is decorated with (6) which is the multiplicity of f on this divisor. The numbers 2 and 3 represent the quotient singularities in U_σ and $U_{\sigma'}$, and the arrow represents the strict transform of C .

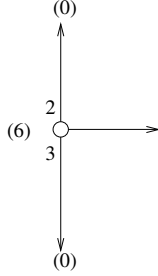

Figure 9.

Let f be a given complex analytic function of two variables defined on an open neighborhood of the origin such that $f(0,0) = 0$.

We can consider the Newton polygon of f . Let $S \in \mathcal{N}(f)$. Assume the line supporting S has equation $p\alpha + q\beta = N$, then we associate to S the vector ${}^t(p, q)$. Then to $\mathcal{N}(f)$, we associate $\{P_1, \dots, P_m\}$. It gives us a simplicial cone subdivision Σ of N^+ . Then we can associate a toric variety U and a birational morphism $\pi : U \rightarrow \mathbb{C}^2$ such that $\pi^{-1}(0) = \cup_{i=1}^m E(P_i)$. Notice that if we forget about the decorations of the arrows and of the vertices, the graph associated to the Newton polygon of f is the graph dual to the divisor $\pi^{-1}(0)$ with two arrows decorated with (0) at the top and the bottom.

Let $\text{inf}_S = cx^{a_S}y^{b_S} \prod_{l=1}^{k_S} (x^q - \mu_l y^p)^{\nu_l}$. The exceptional divisor intersects the proper transform \tilde{C} at k_S points. Let \tilde{C}_l be the union of the components of \tilde{C} which pass through $(\mu_l, 0)$. The divisor π^*f is given by

$$\pi^*f = \sum_{i=1}^m \sum_{l=1}^{k_i} \tilde{C}_{i,l} + \sum_{i=0}^{m-1} N_i E(P_i).$$

If the germ is non degenerate, the components of the proper transform are smooth and transversal to the $E(P_i)$. And the vertices of Newton tree of f represent the $E(P_i)$ and the arrows not decorated with (0) represent the components of \tilde{C} .

If the germ is degenerate: Now if \tilde{C}_l is not smooth or doesn't intersect transversally with $E(P)$, we consider $(\mu_l, 0)$ as the origin in \mathbb{C}^2 identifying $E(P)$ with E_1 . If $\Pi_{(p,q,\mu_l)}^*(f)$ is not in good coordinates, we perform a change of variables which leaves $E(P)$ fixed. We consider the Newton polygon of $f_{\Pi_{(p,q,\mu_l)}}$ and the corresponding morphism $\pi_1 : U_1 \rightarrow U$. And we do the process again until we get the strict transform of C , smooth and transverse to the exceptionnal divisor.

Now recall the following (cf. [14],[27]).

DEFINITION 3.5. *A toroidal variety is a pair (X, B) where X is an algebraic variety and B a Zariski closed subset such that for any $x \in X$ there exist a toric variety (V_x, D_x) with a fixed 0-dimensional orbit x' and neighbourhoods $U_x, U_{x'}$ in complex*

analytic topology of x and x' respectively in X and V_x such that $(U_x, U_x \cap B) = (U_{x'}, D_x \cap U_{x'})$.

With his we have the following:

Theorem 3.6. *There exists a toroidal variety \bar{U} and a birational morphism $\bar{\pi} : \bar{U} \rightarrow (\mathbb{C}^2, 0)$ such that*

$$\bar{\pi}^* f = \sum \tilde{C}_n + \sum N_m E_m$$

and such that the strict transforms of the components of f are smooth with this divisor having only normal crossings. Moreover, Newton tree of f is the dual graph of this divisor and the N_m are the decorations of the corresponding vertices. The singularities of \bar{U} are on the intersections of the divisors E_m , they are cyclic quotient singularities by the group given by the edge determinant of the corresponding edge in the Newton tree. In particular \bar{U} (and the Newton tree) determine the dual graph of smooth resolution via standard resolution of cyclic quotient singularities of \bar{U}

Proof. Let \bar{U} be the variety obtained after the final step iteration of toric blow ups corresponding to subdivisions of the first quadrant corresponding to the Newton diagrams and changes to good systems of coordinates at the points intersection of the proper preimage of the zero set of the power series which singularity get resolved with the exceptional set of the toric blow up. Let $\cup E_m$ be the union of the proper preimages of the exceptional sets of all iterations. For each step, the toric blow up preserves toric structure, but good change of coordinates may destroy toric structure only at the *smooth* point of an exceptional curve at which this coordinate change is made. Denote them P and E_P respectively. Toric blow up at P , produces toric variety with respect to the toric structure in the new coordinate system. The proper preimage of E_P intersects the exceptional set of the toric blow up at P at smooth point. The boundary divisor consists of two smooth at this point, curves (i.e. the proper preimage of E_P and the exceptional curve) and hence has obvious toric structure. \square

REMARK 3.7. *The variety \bar{U} together with the uniformization of sets U_σ providing the cover of \bar{U} also has the canonical structure of orbifold (cf. [1]) or stack. The resulting orbifold is not a global quotient in general. This provides the alternative category in which one has canonical resolution of singularities of f*

REMARK 3.8. *In the next section we shall consider the problem of extendability of 2-forms on the abelian covers $z_i^{m_i} = f_i$ where f_i are irreducible components of a germ $f = 0$ (cf. 4.1). After pull back this abelian cover on \bar{U} the problem becomes about holomorphic extension of forms on resolution of singularities of the abelian cover of \bar{U} ramified over the exceptional set of \bar{U} . Since singularities of \bar{U} are cyclic quotients with exceptional curves near such singularity forming at most two orbits in resolution, one adds to exceptional curves of \bar{U} only curves intersected by at most two other components of exceptional set i.e. resolution of quotient singularities does not add “rupture” curves. Such components in smooth resolution do not add restrictions on extendability (cf. [6]) Hence extendability*

of forms on abelian covers enough to check only on the exceptional curves which appear on \bar{U} .

We shall finish this section with calculation in terms of the Newton tree of the multiplicities of the pull back on the canonical resolution \bar{U} of holomorphic on \mathbb{C}^2 2-form. If v is a vertex on the Newton tree, denote by $\nu_v - 1 = \text{mult}_{E\pi^*}(dx \wedge dy)$, if E is the divisor corresponding to v .

Proposition 3.9. (1) *If the vertex v corresponds to a face of the Newton polygon of f and is decorated by (q, p) then $\nu_v = p + q$.*

(2) *If the vertex v with nearby decorations (q, p) has preceding vertex v_0 with nearby decorations (q_0, p_0) , then $\nu_v = \nu_{v_0}p + \delta$, where $\delta = q - pp_0q_0$.*

Proof. We can compute the differential using the Newton map.

Consider the Newton map:

$$x = x_1^p \mu_k^{p'}, y = x_1^q (y_1 + \mu_k^{q'})$$

Then

$$dx = px_1^{p-1} \mu_k^{p'} dx_1, dy = qx_1^{q-1} (y_1 + \mu_k^{q'}) dx_1 + x_1^q dy_1$$

Then

$$dx \wedge dy = px_1^{p+q-1} \mu_k^{p'} dx_1 \wedge dy_1$$

which proves the first part of the proposition and

$$x^{\nu_v-1} dx \wedge dy = px_1^{\nu_v p + \delta - 1} \mu_k^{\nu_v p'} dx_1 \wedge dy_1$$

because the Newton map is in this case

$$x = x_1^p \mu_k^{p'}, y = x_1^\delta (y_1 + \mu_k^{q'})$$

□

4. Polytopes of quasi-adjunction

In this section, we will show how to compute explicitly polytopes of quasi-adjunction using Newton trees.

We first recall some definitions and results concerning polytopes of quasi-adjunction [6].

4.1. Ideals and polytopes of quasi-adjunction. Let B be a small ball about the origin in \mathbb{C}^2 and let \mathcal{C} be a germ of a plane curve having at 0 a singularity with r branches. Let $f_1(x, y) \cdots f_r(x, y) = 0$ be a local equation of this curve (each f_i is assumed to be irreducible). An abelian cover of type (m_1, \dots, m_r) of ∂B is the link of complete intersection surface singularity

$$V_{m_1, \dots, m_r} : z_1^{m_1} = f_1(x, y), \dots, z_r^{m_r} = f_r(x, y) \quad (1)$$

The covering map is given by $p : (z_1, \dots, z_r, x, y) \rightarrow (x, y)$.

An *ideal of quasi-adjunction* $\mathcal{A}(j_1, \dots, j_r | m_1, \dots, m_r)$ having type $(j_1, \dots, j_r | m_1, \dots, m_r)$ is the ideal in the local ring of the singularity of \mathcal{C} consisting of germs ϕ such that the 2-form:

$$\omega_\phi = \frac{\phi z_1^{j_1} \dots z_r^{j_r} dx \wedge dy}{z_1^{m_1-1} \dots z_r^{m_r-1}} \quad (2)$$

extends to a holomorphic form on a resolution of the singularity of V_{m_1, \dots, m_r} .

Let

$$\mathcal{U} = \{(x_1, \dots, x_r) \in \mathbb{R}^r, 0 \leq x_i < 1\}$$

be the unit cube with coordinates corresponding to f_1, \dots, f_r . Consider an ideal of quasi-adjunction \mathcal{A} . There is a unique polytope $\mathcal{P}(\mathcal{A})$ opensubset in \mathcal{U} such that: For $(m_1, \dots, m_r) \in \mathbb{Z}^r$ and $(j_1, \dots, j_r) \in \mathbb{Z}^r$ with $0 \leq j_i < m_i, 1 \leq i \leq r$

$$\mathcal{A} \subseteq \mathcal{A}(j_1, \dots, j_r | m_1, \dots, m_r) \Leftrightarrow \left(\frac{j_1+1}{m_1}, \dots, \frac{j_r+1}{m_r} \right) \in \mathcal{P}(\mathcal{A})$$

A *face of quasi-adjunction* is a face of the boundary of the polytope $\mathcal{P}(\mathcal{A})$. It follows that it can be characterized as follows. Let E_i be the exceptional curves of an embedded resolution $\pi : \tilde{\mathbb{C}}^2 \rightarrow \mathbb{C}^2$ of $f_1 \cdot \dots \cdot f_r = 0$. Let $N_{i,k} = \text{mult}_{E_k} \pi^*(f_i)$ be the multiplicity of pullback of f_i to $\tilde{\mathbb{C}}^2$, $\nu_k - 1 = \text{mult}_{E_k} \pi^*(dx \wedge dy)$ ⁴ and for a germ $\phi \in \mathcal{O}_{\mathbb{C}^2, (0,0)}$, $e_k(\phi) = \text{mult}_{E_k} \pi^*(\phi)$. Then the face of quasi-adjunction containing $\wp = \left(\frac{j_1+1}{m_1}, \dots, \frac{j_r+1}{m_r} \right) \in \mathcal{U}$ is the face α of the boundary of the set of points satisfying:

$$\sum_i N_{i,k} x_i > \sum_i N_{i,k} - e_k(\phi) - \nu_k \quad (3)$$

for all ϕ in the ideal of quasi-adjunction $\mathcal{A}(j_1, \dots, j_r | m_1, \dots, m_r)$ (and such that $\wp \in \alpha$). In particular for $(j'_1, \dots, j'_r | m'_1, \dots, m'_r)$ for which the corresponding point satisfies (3) the form ω_ϕ extends over all E_i . However for $(j'_1, \dots, j'_r | m'_1, \dots, m'_r)$ on the face itself there exist ϕ in the ideal of quasi-adjunction for which ω_ϕ has pole on one of the exceptional curves.

Finally recall (cf. [18] Prop.4.2) that the whole local ring $\mathcal{O}_{(\mathbb{C}^2, (0,0))}$ is of ideals of quasi-adjunction. Moreover, the convex hull of vectors $(\gamma_1, \dots, \gamma_r)$ such that the \mathbf{R} -divisor $\gamma_1 \text{div}(f_1) + \dots + \gamma_r \text{div}(f_r)$ is log-canonical (here $\text{div}(f)$ denotes the divisor of a function $f(x, y)$) consists of vectors $(\gamma_1, \dots, \gamma_r)$ such that $(-\gamma_1 + 1, \dots, -\gamma_r + 1)$ is the polytope of quasi-adjunction corresponding to the this ideal of quasiadjunction (i.e. $\mathcal{O}_{(\mathbb{C}^2, (0,0))}$). We call this convex hull the *log-canonical wall* of singularity $f_1 \cdot \dots \cdot f_r$. For $r = 1$ we obtain the log-canonical threshold of divisor $\text{div}(f)$.

⁴there should be no confusion with notations used in section 2.1 where ν_i was used to denote the multiplicity of a factor.

4.2. Computation of faces of quasi-adjunction. Let f_1, \dots, f_r a collection of irreducible germs. We consider the Newton tree associated to $f_1 f_2 \cdots f_r$. Denote by \mathcal{V} the set of vertices of the Newton tree. To each $v \in \mathcal{V}$ we associate the linear form

$$l_v(s) = \sum_i N_{v,i}(s_i - 1) + \nu_v \quad (4)$$

where $N_{v,i}$ is the intersection multiplicity of f_i with a curvette C_v and ν_v is computed by Proposition 3.9.

Theorem 4.1. (1) *Let ϕ be a germ, then the polytope of quasi-adjunction associated to ϕ is defined by the set of inequalities*

$$l_v(s) > -e_v(\phi)$$

for all $v \in \mathcal{V}$, where $e_v(\phi)$ is the intersection multiplicity of ϕ with a curvette C_v .

(2) *For all $v \in \mathcal{V}$ there exist ϕ and a face of the polytope of quasi-adjunction associated to ϕ with equation*

$$l_v(s) = -e_v(\phi)$$

The first part of the theorem is a consequence of the discussion of part 3 which says that there is a bijection between the vertices of the Newton tree and the rupture divisors in a resolution, and Proposition 3.1 of [6], which says that we only need those divisors to compute the polytopes of quasi-adjunction.

The proof of the second part will occupy the remain of the section.

4.2.1. The case $r=1$. As we have seen in [6], the polytopes of quasi-adjunction c (which in this case are called the constant of quasi-adjunction) are such that $1 - c$ is an exponent between 0 and 1. We will recover Saito's theorem. We will compute exponents instead of constants of quasi-adjunction.

Let f be an irreducible germ. Its Newton tree is as Figure 10.

We denote $(q, p) = (q_0, p_0)$, the decorations of the first vertex. We assume $q_0 > p_0$. We denote $\delta_i = q_i - p_i p_{i-1} q_{i-1}$.

We have indexed the vertices from 0 to r . The first part of theorem 4.1 says that the constant of quasi-adjunction associated to ϕ is given by $1 - \epsilon(\phi)$ where

$$\epsilon(\phi) = \min_{i=0, \dots, r} \frac{\nu_i + e_i(\phi)}{p_i q_i \prod_{j=i+1}^r p_j}.$$

We denote by

$$\epsilon_i(\phi) = \frac{\nu_i + e_i(\phi)}{p_i q_i \prod_{j=i+1}^r p_j}$$

and we call it the invariant of the vertex v_i associated to ϕ .

We will define a set of ϕ which gives all the exponents and such that the invariant along the horizontal path is decreasing to the minimum and then increasing. We need some technical lemma.

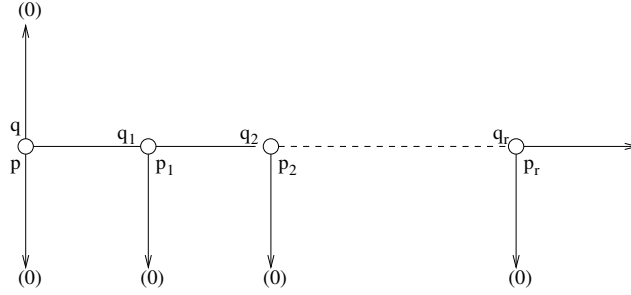

Figure 10.

Lemma 4.2. For i from 0 to r , we have

$$p_i q_i - \nu_i > 0$$

Proof. For $i = 0$, we have $p_0 q_0 - \nu_0 = p_0 q_0 - p_0 - q_0 > 0$ since $p_0 \geq 2$.
Assume that $p_i q_i - \nu_i > 0$.

$$\begin{aligned} p_{i+1} q_{i+1} - \nu_{i+1} &= p_{i+1} (q_i p_i p_{i+1} + \delta_{i+1}) - (\nu_i p_{i+1} + \delta_{i+1}) \\ p_{i+1} q_{i+1} - \nu_{i+1} &= p_{i+1} (p_i q_i p_{i+1} - \nu_i) + (p_{i+1} - 1) \delta_{i+1} > p_i q_i - \nu_i > 0 \end{aligned}$$

□

DEFINITION 4.3. We consider irreducible germs $C'_0, C_0, C_1, \dots, C_r$ with Newton trees as in Figure 11.

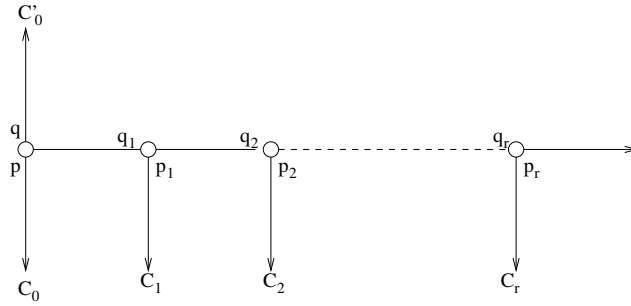

Figure 11.

We define

$$\phi = C_0'^a C_0^b C_1^{c_1} \dots C_r^{c_r}$$

We assume

$$\forall i, 1 \leq i \leq r, 0 \leq c_i < p_i$$

Define

$$\begin{aligned} A_0 &= ap_0 + bq_0 \\ A_{i+1} &= A_i p_{i+1} + c_{i+1} q_{i+1}, i = 0, \dots, r-1 \end{aligned}$$

Lemma 4.4. For i from 0 to $r-1$, we have

$$\epsilon_i(\phi) - \epsilon_{i+1}(\phi) = \frac{\delta_{i+1}}{q_i q_{i+1} \prod_{j=1}^r p_j} (\nu_i - p_i q_i + A_i)$$

Proof.

$$\nu_i q_{i+1} - \nu_{i+1} p_i q_i = \nu_i (p_i q_i p_{i+1} + \delta_{i+1}) - (\nu_i p_{i+1} + \delta_{i+1}) p_i q_i$$

$$\nu_i q_{i+1} - \nu_{i+1} p_i q_i = \delta_{i+1} (\nu_i - p_i q_i)$$

We have to compute $q_{i+1} e_i(\phi) - p_i q_i e_{i+1}(\phi)$.

$$e_i(\phi) = (ap_0 + bq_0) \prod_1^i p_j + q_1 c_1 \prod_2^i p_j + \dots + q_i c_i + p_i q_i (c_{i+1} + \dots + c_r \prod_{j=i+1}^{r-1} p_j)$$

$$\begin{aligned} e_{i+1}(\phi) &= (ap_0 + bq_0) \prod_1^{i+1} p_j + q_1 c_1 \prod_2^{i+1} p_j + \dots + q_i c_i p_{i+1} + q_{i+1} c_{i+1} \\ &\quad + p_{i+1} q_{i+1} (c_{i+2} + \dots + c_r \prod_{j=i+2}^{r-1} p_j) \end{aligned}$$

Then

$$q_{i+1} e_i(\phi) - p_i q_i e_{i+1}(\phi) = \delta_{i+1} A_i$$

□

Lemma 4.5. If $A_{i_0} < p_{i_0} q_{i_0} - \nu_{i_0}$, then $\forall i, i_0 \leq i \leq r, A_i < p_i q_i - \nu_i$.

Proof. Assume $A_i < p_i q_i - \nu_i$.

$$\begin{aligned} A_{i+1} &= A_i p_{i+1} + c_{i+1} q_{i+1} < (p_i q_i - \nu_i) p_{i+1} + q_{i+1} (p_{i+1} - 1) = \\ & q_{i+1} - \nu_{i+1} + p_{i+1} q_{i+1} - q_{i+1} = p_{i+1} q_{i+1} - \nu_{i+1} \end{aligned}$$

□

Next proposition will be used in all the remain of the article.

Proposition 4.6. Let ϕ be as in definition 4.3. Then

$$\epsilon(\phi) = \epsilon_{i_0}(\phi)$$

where i_0 is such that for $0 \leq i < i_0, A_i > p_i q_i - \nu_i$ and $A_{i_0} < p_{i_0} q_{i_0} - \nu_{i_0}$. Moreover, the sequence $\epsilon_i(\phi)$ is decreasing for $i \leq i_0$ and increasing for $i \geq i_0$.

Proof. If, for $0 \leq i \leq i_0 - 1$, we have $A_i > p_i q_i - \nu_i$, then

$$\epsilon_i(\phi) > \epsilon_{i+1}(\phi)$$

Then for $0 \leq i \leq i_0 - 1$

$$\epsilon_i(\phi) > \epsilon_{i_0}(\phi)$$

We have for $i_0 \leq i \leq r$, $A_i < p_i q_i - \nu_i$ and

$$\epsilon_i(\phi) < \epsilon_{i+1}(\phi)$$

□

M. Saito [24] has proven the following

Theorem 4.7. *Let f be an irreducible plane singularity with Newton tree as in Figure 10*

Then the exponents between 0 and 1 are given by the following formula

$$e_i(k_1, k_2, k_3) = \frac{1}{\prod_{j=i+1}^r p_j} \left(\frac{k_1}{p_i} + \frac{k_2}{q_i} \right) + \frac{k_3}{\prod_{j=i+1}^r p_j}$$

where $0 < k_1 < p_i$, $0 < k_2 < q_i$, $\frac{k_1}{p_i} + \frac{k_2}{q_i} < 1$, $0 \leq k_3 < \prod_{j=i+1}^r p_j$ for $0 \leq i \leq r$.

We prove that

Proposition 4.8. *For each i and k_1, k_2, k_3 , there exists ϕ as in proposition 4.6 such that $e_i(k_1, k_2, k_3) = \epsilon_i(\phi) = \epsilon(\phi)$.*

Proof. We have to prove that for each $i, 0 \leq i \leq r$ and for each (k_1, k_2, k_3) there exists ϕ such that

$$\frac{1}{\prod_{j=i+1}^r p_j} \left(\frac{k_1}{p_i} + \frac{k_2}{q_i} \right) + \frac{k_3}{\prod_{j=i+1}^r p_j} = \epsilon_i(\phi)$$

and

$$\epsilon_i(\phi) = \epsilon(\phi)$$

We can write

$$\nu_i = q_i - p_i(p_{i-1}q_{i-1} - \nu_{i-1})$$

$$e_i(\phi) = \alpha_i p_i + \beta_i q_i + \gamma_i p_i q_i$$

Then

$$\frac{\nu_i + e_i(\phi)}{p_i q_i \prod_{j=i+1}^r p_j} = \frac{1}{\prod_{j=i+1}^r p_j} \left(\frac{\beta_i + 1}{p_i} + \frac{\alpha_i - p_{i-1}q_{i-1} + \nu_{i-1}}{q_i} + \gamma_i \right)$$

Let

$$\alpha_i = p_{i-1}q_{i-1} - \nu_{i-1} + k_2, \beta_i = k_1 - 1, \gamma_i = k_3.$$

We have

$$\alpha_i p_i + \beta_i q_i = k_2 p_i + k_1 q_i - \nu_i < p_i q_i - \nu_i$$

Now we show that we can find (a, b, c_1, \dots, c_r) with $0 \leq c_i < p_i$ for $1 \leq i \leq r$, such that

$$\phi = C_0'^a C_0^b C_1^{c_1} \dots C_r^{c_r}.$$

We have $0 \leq k_3 < \prod_{i+1}^r p_j$, then we can write

$$\gamma_i = c_{i+1} + c_{i+2}p_{i+1} + \dots + c_r p_{i+1} \dots p_{r-1}$$

with $0 \leq c_l < p_l$ for $i+1 \leq l \leq r$.

We will show that there exists (a, b, c_1, \dots, c_i) positive integers such that $\alpha_i = A_i$ and we set $\beta_i = c_i < p_i$. We need the following

Lemma 4.9. *Let p, q positive integers prime to each other. Let a be a positive integer $a = pq + k$ with $-p - q < k$. Then there exist $0 \leq n, 0 \leq m < p$ such that $a = np + mq$.*

Proof. Choose a pair $(n, m) \in \mathbb{Z}^2$ such that $a = np + mq$. One can choose m such that $0 \leq m < p$. If $a = pq + k$ with $k > -p - q$ then $n \geq 0$. \square

Lemma 4.10. *For $0 \leq i \leq r$, we have $\nu_i \leq p_i + q_i$.*

Proof. For $i = 0$, we have $\nu_0 = p_0 + q_0$. For $0 < i$,

$$\nu_i = \nu_{i-1}p_i + \delta_{i-1} = \nu_{i-1}p_i + q_i - p_{i-1}q_{i-1}p_i = (\nu_{i-1} - p_{i-1}q_{i-1})p_i + q_i \leq p_i + q_i$$

\square

We have

$$\alpha_i = p_{i-1}q_{i-1} - \nu_{i-1} + k_2.$$

with $k_2 \geq 0$. Then the equation $\alpha_i = \alpha_{i,1}p_{i-1} + \beta_{i,1}q_{i-1}$ admits a solution in positive integers with $\beta_{i-1} < p_{i-1}$.

We have

$$\alpha_{i,1} > p_{i-2}q_{i-2} - \nu_{i-2}$$

Since

$$\alpha_{i,1}p_{i-1} + \beta_{i,1}q_{i-1} > p_{i-1}q_{i-1} - \nu_{i-1}$$

$$\alpha_{i,1}p_{i-1} > (p_{i-1} - \beta_{i,1})q_{i-1} - \nu_{i-1}$$

$$\alpha_{i,1}p_{i-1} > (p_{i-1} - \beta_{i,1})(p_{i-2}q_{i-2}p_{i-1} + \delta_{i-1}) - (\nu_{i-2}p_{i-1} + \delta_{i-1})$$

$$\alpha_{i,1}p_{i-1} > (p_{i-1} - \beta_{i,1} - 1)\delta_{i-1} + (p_{i-2}q_{i-2} - \nu_{i-2})p_{i-1}$$

Then we can write

$$\alpha_{i,1} = \alpha_{i,2}p_{i-2} + \beta_{i,2}q_{i-2}$$

with $0 \leq \beta_{i,2} < p_{i-2}$ and $\alpha_{i,2} > p_{i-3}q_{i-3} - \nu_{i-3}$.

We define $\alpha_i = A_{i-1}, \beta_i = c_i, \alpha_{i,1} = A_{i-2}, \beta_{i,1} = c_{i-1} \dots \alpha_{i,i-1} = A_0, \beta_{i,i-1} = c_1$. We have $A_0 > p_0q_0 - \nu_0$ and we write $A_0 = ap_0 + bq_0$. \square

REMARK 4.11. (1) The last proposition prove that the numbers $e_i(k_1, k_2, k_3)$ are exponents between 0 and 1. Then the bounds for k_1, k_2, k_3 imply that they are all the exponents between 0 and 1 and then we have a new proof of Saito theorem.

(2) We have

$$\min_i \frac{\nu_i}{p_i q_i \prod_{i+1} p_j} = \frac{\nu_0}{p_0 q_0 \prod_1 p_j} = \epsilon_0(1) = \epsilon(1).$$

This is the minimum of the exponents and is called the log-canonical threshold.

(3) For all $i \neq 0$ $1 - \frac{\nu_i}{p_i q_i \prod_{i+1} p_j} = 1 - \epsilon_i(1)$ is an exponent. In fact we can write

$$p_i q_i \prod_{i+1} p_j - q_i + p_i(p_{i-1} q_{i-1} - \nu_{i-1}) = q_i(p_i - 1) + p_i(p_{i-1} q_{i-1} - \nu_{i-1}) + p_i q_i \left(\prod_{i+1} p_j - 1 \right)$$

This is not true that for any ϕ the minimum $\frac{\nu_i + e_i(\phi)}{p_i q_i \prod_{i+1} p_j}$ is an exponent and $1 - \frac{\nu_l + e_l(\phi)}{p_l q_l \prod_{l+1} p_j}$ is an exponent for $l \neq i$. One example is given by $(p_0, q_0) = (2, 3)$, $(p_1, q_1) = (2, 13)$, $(p_2, q_2) = (2, 53)$ and $\phi = C_1 C_2$. We have $23/24 < 50/52 < 102/106$, $23/24$ is an exponent, but $2/52$ and $4/106$ are not. This remark is connected to the monodromy conjecture and the recent work of Nemethi and Veys [21].

We can show that for each vertex there is an exponent obtained by this vertex and no other.

Proposition 4.12. For each i , there exist ϕ such that $\epsilon_i(\phi) = \epsilon(\phi)$ and for all ϕ' and $j \neq i$, $\epsilon(\phi) \neq \epsilon_j(\phi')$.

To prove this result we need some lemma.

Lemma 4.13. For all $j > i$, and all $k < i$, we have

$$\frac{1}{\prod_{i+1} p_l} \left(\frac{1}{p_i} + \frac{1}{q_i} \right) \neq \frac{1}{\prod_{j+1} p_l} \left(\frac{k_1}{p_j} + \frac{k_2}{q_j} + k_3 \right)$$

and

$$\frac{1}{\prod_{i+1} p_l} \left(\frac{1}{p_i} + \frac{1}{q_i} \right) \neq \frac{1}{\prod_{k+1} p_l} \left(\frac{k_1}{p_k} + \frac{k_2}{q_k} + k_3 \right)$$

Proof. Assume that there exists (k_1, k_2, k_3) such that

$$\frac{1}{\prod_{i+1} p_l} \left(\frac{1}{p_i} + \frac{1}{q_i} \right) = \frac{1}{\prod_{j+1} p_l} \left(\frac{k_1}{p_j} + \frac{k_2}{q_j} + k_3 \right)$$

that is

$$\frac{1}{\prod_{i+1} p_l} \left(\frac{1}{p_i} + \frac{1}{q_i} \right) = \left(\frac{k_1}{p_j} + \frac{k_2}{q_j} + k_3 \right)$$

We have $\frac{k_1}{p_j} + \frac{k_2}{q_j} + k_3 \geq \frac{1}{p_j}$ and $\frac{1}{\prod_{i+1}^j p_l} (\frac{1}{p_i} + \frac{1}{q_i}) < \frac{1}{p_j}$. Then the first assertion is proved.

Assume that there exists (k_1, k_2, k_3) such that

$$\frac{1}{\prod_{i+1}^j p_l} (\frac{1}{p_i} + \frac{1}{q_i}) = \frac{1}{\prod_{k+1}^j p_l} (\frac{k_1}{p_k} + \frac{k_2}{q_k} + k_3),$$

that is

$$\frac{1}{p_i} + \frac{1}{q_i} = \frac{1}{\prod_{k+1}^i p_l} (\frac{k_1}{p_k} + \frac{k_2}{q_k} + k_3).$$

On the left hand side, the denominator is $p_i q_i$. On the right hand side, the denominator is a divisor of $q_k \prod_k^i p_l$. But $p_i q_i > q_k \prod_k^i p_l$. The second assertion is proved. \square

Now we can prove proposition

Proof. Consider a vertex of the Newton tree v decorated with (p_i, q_i) .

Consider the exponent $\frac{1}{\prod_{i+1}^j p_l} (\frac{1}{p_i} + \frac{1}{q_i})$. We found a ϕ such that

$$\frac{1}{\prod_{i+1}^j p_l} (\frac{1}{p_i} + \frac{1}{q_i}) = \frac{\nu_i + e_i(\phi)}{p_i q_i \prod_{i+1}^j p_l} < \frac{\nu_j + e_j(\phi)}{p_j q_j \prod_{j+1}^l p_l}$$

for $j \neq i$. Assume there exists $m \neq i$ and ϕ' such that

$$\frac{1}{\prod_{i+1}^j p_l} (\frac{1}{p_i} + \frac{1}{q_i}) = \frac{\nu_m + e_m(\phi')}{p_m q_m \prod_{m+1}^j p_l} < \frac{\nu_j + e_j(\phi')}{p_j q_j \prod_{j+1}^l p_l}$$

for $j \neq m$. Since $\frac{\nu_m + e_m(\phi')}{p_m q_m \prod_{m+1}^j p_l}$ is $1 - c$ with c a constant of quasi-adjunction, it is an exponent and so can be written $\frac{1}{\prod_{j+1}^l p_l} (\frac{k_1}{p_j} + \frac{k_2}{q_j} + k_3)$. This is not possible using the previous lemma. Then the exponent $\frac{1}{\prod_{i+1}^j p_l} (\frac{1}{p_i} + \frac{1}{q_i})$ is given by the vertex v and no other. \square

4.2.2. Induction step. We want to prove the theorem by induction. We need the following proposition.

Proposition 4.14. *The intersection of the polytopes of quasi-adjunction of f_1, \dots, f_r with the hyperplane $s_1 = 1$ are the polytopes of quasi-adjunction of f_2, \dots, f_r .*

Proof. The polytopes of quasi-adjunction of $f_1 \cdots f_r$ are given by inequalities

$$\sum_i^r N_{v,i}(s_i - 1) + \nu_v + e_v(\phi) > 0$$

where v runs over all the vertices of the Newton tree of $f_1 \cdots f_r$. We have to show that when $s_1 = 1$ we only need inequalities with v running over the vertices of the Newton tree of $f_2 \cdots f_r$.

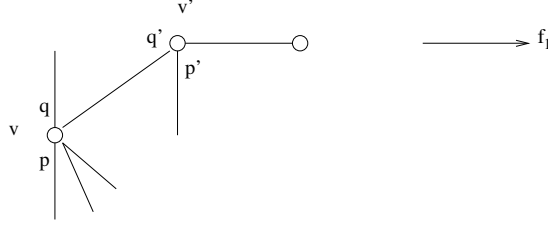

Figure 12.

To delete f_1 we cut an horizontal edge e arising from a vertex v . We have two cases. Either the edge e ends by an arrow and we do not delete any vertices except eventually v , or we delete a line of vertices. We study this case.

Let v and v' be the two vertices ending e . If we cut e the vertex v' is deleted. We prove that the inequality

$$\sum_2^r N_{v,i}(s_i - 1) + \nu_v + e_v(\phi) > 0$$

implies

$$\sum_2^r N_{v',i}(s_i - 1) + \nu_{v'} + e_{v'}(\phi) > 0$$

The vertex v is decorated with (q, p) (neither one on e) and the vertex v' is decorated with (q', p') (with q' on e), we denote by $\delta = q' - pqp' > 0$. We have, for $i \neq 1$, $N_{v',i} = p'N_{v,i}$, $\nu_{v'} = \nu_v p' + \delta$, and we can write

$$e_v(\phi) = a + \beta bpq + cpq, e_{v'}(\phi) = ap' + \alpha bp' + cq'$$

$$\begin{aligned} & \sum_2^r N_{v',i}(s_i - 1) + \nu_{v'} + e_{v'}(\phi) \\ &= \left(\sum_2^r N_{v,i}(s_i - 1) + \nu_v + e_v(\phi) \right) p' + p'b(\alpha - \beta pq) + (c + 1)\delta \\ &> \sum_2^r N_{v,i}(s_i - 1) + \nu_v + e_v(\phi) \end{aligned}$$

for all ϕ . The same computation shows that if v'' is the vertex attached to v' on the Newton tree of f_1 , we have the inequality

$$\sum_2^r N_{v'',i}(s_i - 1) + \nu_{v''} + e_{v''}(\phi) > 0$$

implies

$$\sum_2^r N_{v'',i}(s_i - 1) + \nu_{v''} + e_{v''}(\phi) > 0$$

Now if v is not a vertex on the Newton tree of $f_2 \cdots f_r$ the inequality corresponding to v is not needed from Proposition 3.1 in [6]. □

Now we can prove the theorem. We use induction on the number r of irreducible branches. It is true for $r = 1$. Assume it is true for any set of $r - 1$ of irreducible functions. Consider f_1, \dots, f_r . We consider the intersection of the polytopes of quasi-adjunction of f_1, \dots, f_r with the hyperplane $s_1 = 1$. This gives the polytopes of quasi-adjunction of f_2, \dots, f_r . Then all the vertices on the Newton tree of $f_2 \cdots f_r$ contribute. If we have all the vertices of $f_1 \cdots f_r$ we are done. Otherwise we consider all the possible choices of $r - 1$ functions amongst f_1, \dots, f_r . All the vertices of the Newton tree of $f_1 \cdots f_r$ will appear except in the two cases:

- (1) $r = 2$ and v is decorated with $(q, 1)$
- (2) $r = 3$ and v is decorated with $(1, 1)$.

4.2.3. Exceptional cases. The rest of the section is devoted to the proof of these particular cases.

We have to consider those cases separately.

Case I.1

This is the case where v is connected by an edge to the arrows representing f_1 and f_2 .

We consider first the case where we have only one vertex.

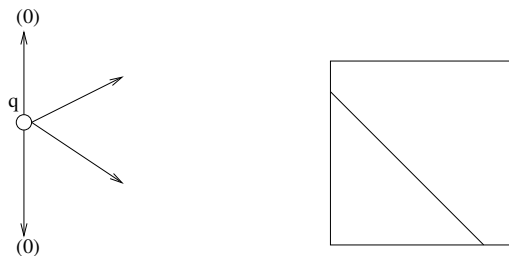

Figure 13.

The log canonical threshold is $q(s_1 - 1) + q(s_2 - 1) + q + 1 > 0$.

The polytopes of quasi-adjunction are given by the following inequalities:

$$\begin{array}{rcccc} q_0 p_0 \prod_1^r p_j (s_1 - 1) & + q_0 p_0 \prod_1^r p_j (s_2 - 1) & + \nu_0 & + e_0(\phi) & > 0 \\ \dots & & & & \\ q_r p_r (s_1 - 1) & + q_r p_r (s_2 - 1) & + \nu_r & + e_r(\phi) & > 0 \\ q(s_1 - 1) & + q(s_2 - 1) & + \nu & + e(\phi) & > 0 \end{array}$$

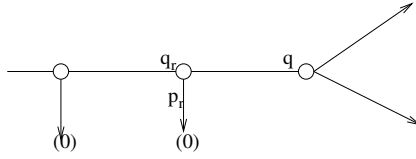

Figure 14.

All the hyperplanes defined by the equality are parallel.

If we could erase the last inequality, we would have the inequalities defining the polytopes of quasi-adjunction in the case the two germs separate on the vertex decorated with (q_r, p_r) (Figure 15).

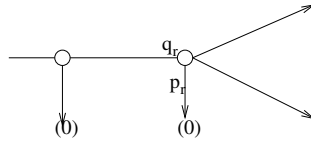

Figure 15.

But we know that the number of intersections of the polytopes of quasi-adjunction with the line $s_1 = s_2$ inside the cube is the Milnor number. The Milnor numbers of the two singularities differ by $q - p_r q_r$. Then we need all the inequalities.

EXAMPLE 4.15. (see Figure 16)

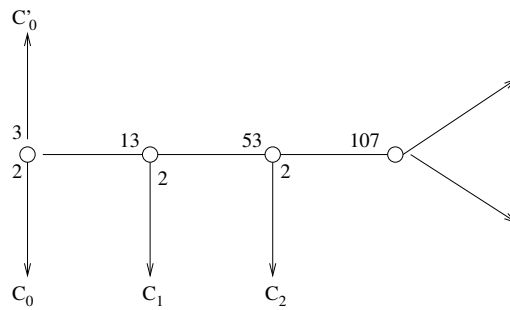

Figure 16.

The polytopes of quasi-adjunction are given by

$$\begin{aligned} 24(s_1 - 1) + 24(s_2 - 1) + 5 + e_0(\phi) &> 0 \\ 52(s_1 - 1) + 52(s_2 - 1) + 11 + e_1(\phi) &> 0 \\ 106(s_1 - 1) + 106(s_2 - 1) + 23 + e_2(\phi) &> 0 \\ 107(s_1 - 1) + 107(s_2 - 1) + 24 + e(\phi) &> 0 \end{aligned}$$

We take $\phi = C'_0 C_1 C_2$ and the corresponding face of quasi-adjunction is given by

$$107(s_1 - 1) + 107(s_2 - 1) + 111 = 0$$

Case I.2

We first consider the following case (see Figure 17).

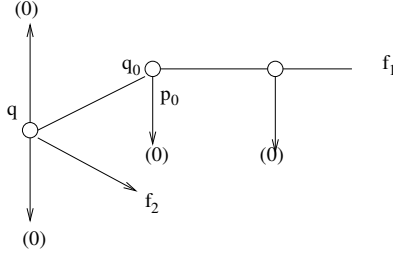

Figure 17.

We consider $\phi = 1$.

We have the set of following inequalities to compute the log-canonical wall.

$$\begin{aligned} q \prod_0^r p_j (s_1 - 1) &+ q(s_2 - 1) &+ \nu &> 0 \\ q_0 p_0 \prod_1^r p_j (s_1 - 1) &+ q p_0 (s_2 - 1) &+ \nu_0 &> 0 \\ q_i p_i \prod_{i+1}^r p_j (s_1 - 1) &+ q \prod_0^i p_j (s_2 - 1) &+ \nu_i &> 0 \end{aligned}$$

Since we have for all i from 0 to $r - 1$,

$$1 - \frac{\nu_i}{p_i q_i \prod_{i+1}^r p_j} > 1 - \frac{\nu_{i+1}}{p_{i+1} q_{i+1} \prod_{i+2}^r p_j}$$

and

$$1 - \frac{\nu_i}{q \prod_0^i p_j} > 1 - \frac{\nu_{i+1}}{q \prod_0^{i+1} p_j}$$

the inequality $q_0 p_0 \prod_1^r p_j (s_1 - 1) + q p_0 (s_2 - 1) + \nu_0 > 0$ implies the inequalities $q_i p_i \prod_{i+1}^r p_j (s_1 - 1) + q \prod_0^i p_j (s_2 - 1) + \nu_i > 0$ for i from 1 to r . We are left with the two inequalities

$$\begin{aligned} q \prod_0^r p_j (s_1 - 1) &+ q(s_2 - 1) &+ \nu &> 0 \\ q_0 p_0 \prod_1^r p_j (s_1 - 1) &+ q p_0 (s_2 - 1) &+ \nu_0 &> 0 \end{aligned}$$

We compute the intersection of the two lines $q \prod_0^r p_j (s_1 - 1) + q(s_2 - 1) + \nu = 0$ and $q_0 p_0 \prod_1^r p_j (s_1 - 1) + q p_0 (s_2 - 1) + \nu_0 = 0$, which is $(s_1 = 1 - \frac{1}{\prod_0^r p_j}, s_2 = 1 - \frac{1}{q})$, which means that the log-canonical wall is a breaking line and that the equation $q \prod_0^r p_j (s_1 - 1) + q(s_2 - 1) + \nu = 0$ does occur.

Now we consider (see Figure 18)

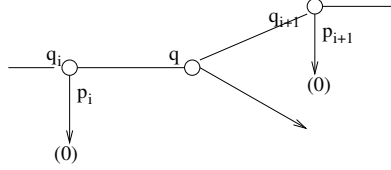

Figure 18.

We chose ϕ as in proposition 4.6 such that

$$\max_j \left(1 - \frac{\nu_j + e_j(\phi)}{p_j q_j \prod_{j+1}^r p_l} \right) = 1 - \frac{1}{\prod_{i+2}^r p_l} \left(\frac{1}{q_{i+1}} + \frac{1}{p_{i+1}} \right)$$

That means that with the notation of Definition 4.3 we have $\phi = C_0^{a'} C_0^b C_1^{c_1} \dots C_i^{c_i}$, $e_i(\phi) = A_i = p_i q_i - \nu_i + 1$.

We have to consider

$$\begin{aligned} q_j p_j \prod_{j+1}^r p_l (s_1 - 1) + q_j p_j \prod_{j+1}^i p_l (s_2 - 1) + \nu_j + e_j(\phi) &> 0, j < i \\ q_i p_i \prod_{i+1}^r p_l (s_1 - 1) + q_i p_i (s_2 - 1) + \nu_i + e_i(\phi) &> 0 \\ q \prod_{i+1}^r p_l (s_1 - 1) + q(s_2 - 1) + \nu + e(\phi) &> 0 \\ q_{i+1} p_{i+1} \prod_{i+2}^r p_l (s_1 - 1) + q p_{i+1} (s_2 - 1) + \nu_{i+1} + e_{i+1}(\phi) &> 0 \\ q_j p_j \prod_{j+1}^r p_l (s_1 - 1) + q \prod_{i+1}^j p_l (s_2 - 1) + \nu_j + e_j(\phi) &> 0, j > i + 1 \end{aligned}$$

Since, for $j \geq i + 1$

$$1 - \frac{\nu_j + e_j(\phi)}{p_j q_j \prod_{j+1}^r p_l} > 1 - \frac{\nu_{j+1} + e_{j+1}(\phi)}{p_{j+1} q_{j+1} \prod_{j+2}^r p_l}$$

and

$$1 - \frac{\nu_j + e_j(\phi)}{q \prod_{i+1}^j p_l} > 1 - \frac{\nu_{j+1} + e_{j+1}(\phi)}{q \prod_{i+1}^{j+1} p_l},$$

because $\nu_{j+1} + e_{j+1}(\phi) - (\nu_j + e_j(\phi)) p_{j+1} = \delta_{j+1}$. Then the inequality $q_{i+1} p_{i+1} \prod_{i+2}^r p_l (s_1 - 1) + q p_{i+1} (s_2 - 1) + \nu_{i+1} + e_{i+1}(\phi) > 0$ implies the inequalities $q_j p_j \prod_{j+1}^r p_l (s_1 - 1) + q \prod_{i+1}^j p_l (s_2 - 1) + \nu_j + e_j(\phi) > 0, j > i + 1$.

We have, for $j \leq i$,

$$1 - \frac{\nu_j + e_j(\phi)}{p_j q_j \prod_{j+1}^r p_l} > 1 - \frac{\nu_{j-1} + e_{j-1}(\phi)}{p_{j-1} q_{j-1} \prod_j^r p_l}$$

$$1 - \frac{\nu_j + e_j(\phi)}{p_j q_j \prod_{j+1}^i p_l} > 1 - \frac{\nu_{j-1} + e_{j-1}(\phi)}{p_{j-1} q_{j-1} \prod_j^i p_l}$$

Then the inequality $q_i p_i \prod_{i+1} p_l (s_1 - 1) + q_i p_i (s_2 - 1) + \nu_i + e_i(\phi) > 0$ implies the inequalities $q_j p_j \prod_{j+1} p_l (s_1 - 1) + q_j p_j \prod_{j+1}^i p_l (s_2 - 1) + \nu_j + e_j(\phi) > 0, j < i$.

Then we are left with the inequalities

$$\begin{aligned} q_i p_i \prod_{i+1} p_l (s_1 - 1) + q_i p_i (s_2 - 1) + \nu_i + e_i(\phi) &> 0 \\ q \prod_{i+1} p_l (s_1 - 1) + q (s_2 - 1) + \nu + e(\phi) &> 0 \\ q_{i+1} p_{i+1} \prod_{i+2} p_l (s_1 - 1) + q p_{i+1} (s_2 - 1) + \nu_{i+1} + e_{i+1}(\phi) &> 0 \end{aligned}$$

The second one implies the first one. In fact since $e_i(\phi) = p_i q_i - \nu_i + 1 = e(\phi)$, we have

$$\begin{aligned} 1 - \frac{\nu_i + e_i(\phi)}{p_i q_i \prod_{i+1}^r p_l} &< 1 - \frac{\nu + e(\phi)}{q \prod_{i+1}^r p_l} \\ 1 - \frac{\nu_i + e_i(\phi)}{p_i q_i} &< 1 - \frac{\nu + e(\phi)}{q} \end{aligned}$$

Then finally we have to consider two inequalities

$$\begin{aligned} q \prod_{i+1} p_l (s_1 - 1) + q (s_2 - 1) + \nu + e(\phi) &> 0 \\ q_{i+1} p_{i+1} \prod_{i+2} p_l (s_1 - 1) + q p_{i+1} (s_2 - 1) + \nu_{i+1} + e_{i+1}(\phi) &> 0 \end{aligned}$$

The intersection point of the lines $q \prod_{i+1} p_l (s_1 - 1) + q (s_2 - 1) + \nu + e(\phi) = 0$ and $q_{i+1} p_{i+1} \prod_{i+2} p_l (s_1 - 1) + q p_{i+1} (s_2 - 1) + \nu_{i+1} + e_{i+1}(\phi) = 0$ is $(s_1 = 1 - \frac{1}{\prod_{i+1}^r p_j}, s_2 = 1 - \frac{1}{q})$. Then we have a polytope of quasi-adjunction with a broken line as face and the inequality $q \prod_{i+1} p_l (s_1 - 1) + q (s_2 - 1) + \nu + e(\phi) = 0$ does occur.

EXAMPLE 4.16. (see Figure 19)

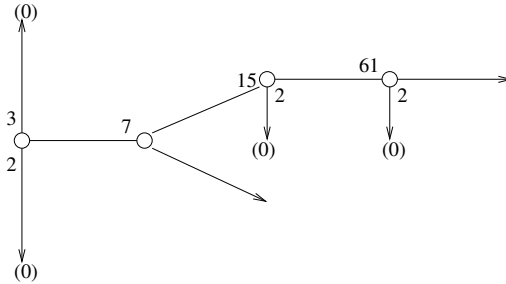

Figure 19.

We have a face of quasi-adjunction given by

$$28(s_1 - 1) + 7(s_2 - 1) + 8 > 0, 60(s_1 - 1) + 14(s_2 - 1) + 17 > 0$$

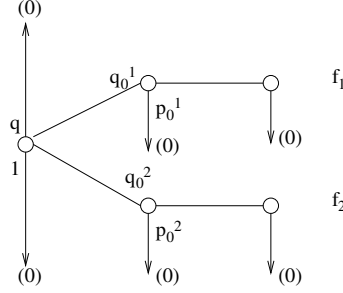

Figure 20.

Case I.3 (See Figure 20)

The log-canonical wall is given by the equations

$$\begin{array}{llll}
q \prod_0^{r^1} p_l^1(s_1 - 1) & + q \prod_0^{r^2} p_l^2(s_2 - 1) & + \nu & > 0 \\
p_0^1 q_0^1 \prod_1^{r^1} p_l^1(s_1 - 1) & + q p_0^1 \prod_0^{r^2} p_l^2(s_2 - 1) & + \nu_0^1 & > 0 \\
p_j^1 q_j^1 \prod_{j+1}^{r^1} p_l^1(s_1 - 1) & + q \prod_0^j p_l^1 \prod_0^{r^2} p_l^2(s_2 - 1) & + \nu_j^1 & > 0, 0 < j < r^1 \\
q p_0^2 \prod_0^{r^1} p_l^1(s_1 - 1) & + p_0^2 q_0^2 \prod_1^{r^2} p_l^2(s_2 - 1) & + \nu_0^2 & > 0 \\
q \prod_0^k p_l^2 \prod_0^{r^1} p_l^1(s_1 - 1) & + p_k^2 q_k^2 \prod_{k+1}^{r^2} p_l^2(s_2 - 1) & + \nu_k^2 & > 0, 0 < k < r^2
\end{array}$$

We have

$$1 - \frac{\nu_j^1}{p_j^1 q_j^1 \prod_{j+1}^{r^1} p_l^1} > 1 - \frac{\nu_{j+1}^1}{p_{j+1}^1 q_{j+1}^1 \prod_{j+2}^{r^1} p_l^1}$$

and

$$1 - \frac{\nu_j^1}{q \prod_0^j p_l^1 \prod_0^{r^2} p_l^2} > 1 - \frac{\nu_{j+1}^1}{q \prod_0^{j+1} p_l^1 \prod_0^{r^2} p_l^2}$$

Then we have to consider the three inequalities

$$\begin{array}{llll}
q \prod_0^{r^1} p_l^1(s_1 - 1) & + q \prod_0^{r^2} p_l^2(s_2 - 1) & + \nu & > 0 \\
p_0^1 q_0^1 \prod_1^{r^1} p_l^1(s_1 - 1) & + q p_0^1 \prod_0^{r^2} p_l^2(s_2 - 1) & + \nu_0^1 & > 0 \\
q p_0^2 \prod_0^{r^1} p_l^1(s_1 - 1) & + p_0^2 q_0^2 \prod_1^{r^2} p_l^2(s_2 - 1) & + \nu_0^2 & > 0
\end{array}$$

We show that the three lines

$$\begin{array}{llll}
(0) & q \prod_0^{r^1} p_l^1(s_1 - 1) & + q \prod_0^{r^2} p_l^2(s_2 - 1) & + \nu = 0 \\
(1) & p_0^1 q_0^1 \prod_1^{r^1} p_l^1(s_1 - 1) & + q p_0^1 \prod_0^{r^2} p_l^2(s_2 - 1) & + \nu_0^1 = 0 \\
(2) & q p_0^2 \prod_0^{r^1} p_l^1(s_1 - 1) & + p_0^2 q_0^2 \prod_1^{r^2} p_l^2(s_2 - 1) & + \nu_0^2 = 0
\end{array}$$

constitute the log-canonical wall.

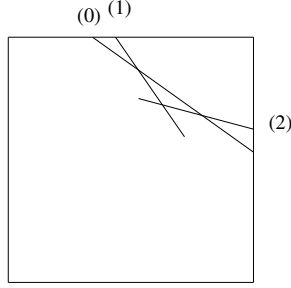

Figure 21.

We have

$$1 - \frac{\nu_0^1}{p_0^1 q_0^1 \prod_1^{r_1} p_l^1} > 1 - \frac{\nu}{q \prod_0^{r_1} p_l^1}$$

Then the intersection of the line (1) with the line $\{s_2 = 1\}$ is greater than the intersection of the line (0) with $\{s_2 = 1\}$. The same for the intersection of (2) and $\{s_1 = 1\}$.

Now we show that the intersection of the lines (1) and (2) is on the same side of the line (0) than the origin. The intersection of (1) and (2) is given by

$$(q_0^1 q_0^2 - q^2 p_0^1 p_0^2) \prod_0^{r_1} p_l^1 (s_1 - 1) + \nu_0^1 q_0^2 - \nu_0^2 q p_0^1 = 0$$

$$(q_0^1 q_0^2 - q^2 p_0^1 p_0^2) \prod_0^{r_2} p_l^2 (s_2 - 1) + \nu_0^2 q_0^1 - \nu_0^1 q p_0^2 = 0$$

We have

$$(q_0^1 q_0^2 - q^2 p_0^1 p_0^2) = q(\delta^1 p_0^2 + \delta^2 p_0^1) + \delta^1 \delta^2$$

$$\nu_0^1 q_0^2 - \nu_0^2 q p_0^1 = q(\delta^1 p_0^2 - \delta^2 p_0^1) + \delta^1 \delta^2 + \nu p_0^1 \delta^2$$

A simple computation gives the result.

Then the log canonical wall is given by the three lines

$$\begin{array}{llll} (0) & q \prod_0^{r_1} p_l^1 (s_1 - 1) & + q \prod_0^{r_2} p_l^2 (s_2 - 1) & + \nu = 0 \\ (1) & p_0^1 q_0^1 \prod_1^{r_1} p_l^1 (s_1 - 1) & + q p_0^1 \prod_0^{r_2} p_l^2 (s_2 - 1) & + \nu_0^1 = 0 \\ (2) & q p_0^2 \prod_0^{r_1} p_l^1 (s_1 - 1) & + p_0^2 q_0^2 \prod_1^{r_2} p_l^2 (s_2 - 1) & + \nu_0^2 = 0 \end{array}$$

and the first vertex does occur.

EXAMPLE 4.17. (see Figure 22)

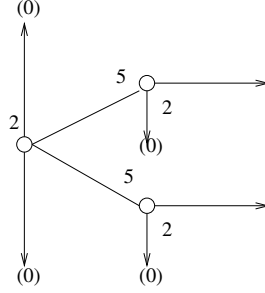

Figure 22.

The log-canonical wall is given by the three inequalities

$$\begin{aligned} 4(s_1 - 1) + 4(s_2 - 1) + 2 &> 0 \\ 10(s_1 - 1) + 8(s_2 - 1) + 5 &> 0 \\ 8(s_1 - 1) + 10(s_2 - 1) + 5 &> 0 \end{aligned}$$

Now we study the case where the separation occurs as in Figure 23.

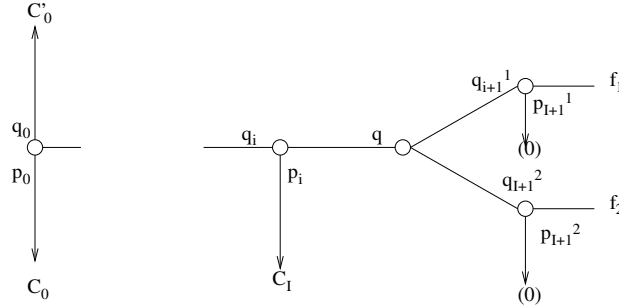

Figure 23.

We consider ϕ such that

$$1 - \frac{1}{\prod_{i+2}^{r_1} p_i^1} \left(\frac{1}{q_{i+1}^1} + \frac{1}{p_{i+1}^1} \right) = 1 - \frac{\nu_{i+1}^1 + e_{i+1}^1(\phi)}{q_{i+1}^1 p_{i+1}^1 \prod_{i+2}^{r_1} p_i^1}$$

is $\max_{0 \leq j \leq r_1} 1 - \frac{\nu_j^1 + e_j^1(\phi)}{q_j^1 p_j^1 \prod_{j+1}^{r_1} p_i^1}$ and

$$1 - \frac{1}{\prod_{i+2}^{r_2} p_i^2} \left(\frac{1}{q_{i+1}^2} + \frac{1}{p_{i+1}^2} \right) = 1 - \frac{\nu_{i+1}^2 + e_{i+1}^2(\phi)}{q_{i+1}^2 p_{i+1}^2 \prod_{i+2}^{r_2} p_i^2}$$

is $\max_{0 \leq j \leq r^2} 1 - \frac{\nu_j^2 + e_j^2(\phi)}{q_j^2 p_j^2 \prod_{l=j+1}^{r^2} p_l^2}$.

This can be achieved with $\phi = C_0^{a'} C_0^b \cdots C_i^{c_i}$ with $A_i = p_i q_i - \nu_i + 1$ with notations of 4.6.

We have to consider the inequalities

$$\begin{aligned}
& q_j p_j \prod_{l=j+1}^{r^1} p_l^1 (s_1 - 1) + q_j p_j \prod_{l=j+1}^{r^2} p_l^2 (s_2 - 1) + \nu_j + e_j(\phi) > 0, 0 \leq j < i \\
& q_i p_i \prod_{l=i+1}^{r^1} p_l^1 (s_1 - 1) + q_i p_i \prod_{l=i+1}^{r^2} p_l^2 (s_2 - 1) + \nu_i + e_i(\phi) > 0 \\
& q \prod_{l=i+1}^{r^1} p_l^1 (s_1 - 1) + q \prod_{l=i+1}^{r^2} p_l^2 (s_2 - 1) + \nu + e(\phi) > 0 \\
& q_{i+1}^1 p_{i+1}^1 \prod_{l=i+2}^{r^1} p_l^1 (s_1 - 1) + q p_{i+1}^1 \prod_{l=i+2}^{r^2} p_l^2 (s_2 - 1) + \nu_{i+1}^1 + e_{i+1}^1(\phi) > 0 \\
& q p_{i+1}^2 \prod_{l=i+2}^{r^1} p_l^1 (s_1 - 1) + q_{i+1}^2 p_{i+1}^2 \prod_{l=i+2}^{r^2} p_l^2 (s_2 - 1) + \nu_{i+1}^2 + e_{i+1}^2(\phi) > 0 \\
& q_n^1 p_n^1 \prod_{l=n+1}^{r^1} p_l^1 (s_1 - 1) + q \prod_{l=i+1}^n p_l^1 \prod_{l=i+2}^{r^2} p_l^2 (s_2 - 1) + \nu_n^1 + e_n^1(\phi) > 0, i+1 < n \leq r^1 \\
& q \prod_{l=i+1}^m p_l^1 \prod_{l=i+2}^{r^1} p_l^1 (s_1 - 1) + q_m p_m^2 \prod_{l=i+2}^{r^2} p_l^2 (s_2 - 1) + \nu_m^2 + e_m^2(\phi) > 0, i+1 < m \leq r^2
\end{aligned}$$

where for $0 \leq j < i$ $p_j = p_j^1 = p_j^2$ and $q_j = q_j^1 = q_j^2$.

As before, we don't need the two last sets of inequalities.

We have

$$1 - \frac{\nu_j + e_j(\phi)}{q_j p_j \prod_{l=j+1}^{r^1} p_l^1} > 1 - \frac{\nu_{j-1} + e_{j-1}(\phi)}{q_{j-1} p_{j-1} \prod_{l=j}^{r^1} p_l^1}$$

and

$$1 - \frac{\nu_j + e_j(\phi)}{q_j p_j \prod_{l=j+1}^{r^2} p_l^2} > 1 - \frac{\nu_{j-1} + e_{j-1}(\phi)}{q_{j-1} p_{j-1} \prod_{l=j}^{r^2} p_l^2}$$

Then we don't need either the first set of inequalities. We are left with

$$\begin{aligned}
& q_i p_i \prod_{l=i+1}^{r^1} p_l^1 (s_1 - 1) + q_i p_i \prod_{l=i+1}^{r^2} p_l^2 (s_2 - 1) + \nu_i + e_i(\phi) > 0 \\
& q \prod_{l=i+1}^{r^1} p_l^1 (s_1 - 1) + q \prod_{l=i+1}^{r^2} p_l^2 (s_2 - 1) + \nu + e(\phi) > 0 \\
& q_{i+1}^1 p_{i+1}^1 \prod_{l=i+2}^{r^1} p_l^1 (s_1 - 1) + q p_{i+1}^1 \prod_{l=i+2}^{r^2} p_l^2 (s_2 - 1) + \nu_{i+1}^1 + e_{i+1}^1(\phi) > 0 \\
& q p_{i+1}^2 \prod_{l=i+2}^{r^1} p_l^1 (s_1 - 1) + q_{i+1}^2 p_{i+1}^2 \prod_{l=i+2}^{r^2} p_l^2 (s_2 - 1) + \nu_{i+1}^2 + e_{i+1}^2(\phi) > 0
\end{aligned}$$

We show that we don't need the first inequality and that the three last give a polytope of quasi-adjunction. Then the second inequality does occur.

We have

$$\begin{aligned}
1 - \frac{\nu_i + e_i(\phi)}{q_i p_i \prod_{l=i+1}^{r^1} p_l^1} &< 1 - \frac{\nu + e(\phi)}{q \prod_{l=i+1}^{r^1} p_l^1} \\
1 - \frac{\nu_i + e_i(\phi)}{q_i p_i \prod_{l=i+1}^{r^2} p_l^2} &< 1 - \frac{\nu + e(\phi)}{q \prod_{l=i+1}^{r^2} p_l^2}
\end{aligned}$$

then the second inequality implies the first one.

We consider

$$\begin{aligned}
(0) & q \prod_{l=i+1}^{r^1} p_l^1 (s_1 - 1) + q \prod_{l=i+1}^{r^2} p_l^2 (s_2 - 1) + \nu + e(\phi) = 0 \\
(1) & q_{i+1}^1 p_{i+1}^1 \prod_{l=i+2}^{r^1} p_l^1 (s_1 - 1) + q p_{i+1}^1 \prod_{l=i+2}^{r^2} p_l^2 (s_2 - 1) + \nu_{i+1}^1 + e_{i+1}^1(\phi) = 0 \\
(2) & q p_{i+1}^2 \prod_{l=i+2}^{r^1} p_l^1 (s_1 - 1) + q_{i+1}^2 p_{i+1}^2 \prod_{l=i+2}^{r^2} p_l^2 (s_2 - 1) + \nu_{i+1}^2 + e_{i+1}^2(\phi) = 0
\end{aligned}$$

As before, we show that the abscissa of the intersection of line (1) with $\{s_2 = 1\}$ is greater than the abscissa of the intersection of line (0) with $\{s_2 = 1\}$. In fact, we have

$$1 - \frac{\nu_{i+1} + e_{i+1}(\phi)}{q_{i+1}p_{i+1} \prod_{l=i+2}^{r-1} p_l^1} > 1 - \frac{\nu + e(\phi)}{q \prod_{l=i+1}^{r-1} p_l^1}$$

since

$$(\nu + e(\phi))q_{i+1}^1 - q(\nu_{i+1} + e_{i+1}(\phi)) = \delta^1(e(\phi) + \nu - q) = \delta^1$$

since $e(\phi) = p_i q_i - \nu_i + 1$. Now, the intersection point of (1) and (2) is given by

$$\begin{aligned} & (q_{i+1}^1 q_{i+1}^2 - q^2 p_{i+1}^1 p_{i+1}^2) \prod_{l=i+1}^{r-1} p_l^1 (s_1 - 1) + \\ & q_{i+1}^2 \nu_{i+1}^1 - q p_{i+1}^1 \nu_{i+1}^2 + e_{i+1}^1(\phi) q_{i+1}^2 - e_{i+1}^2(\phi) q p_{i+1}^1 = 0 \\ & (q_{i+1}^1 q_{i+1}^2 - q^2 p_{i+1}^1 p_{i+1}^2) \prod_{l=i+1}^{r-2} p_l^2 (s_2 - 1) + \\ & q_{i+1}^1 \nu_{i+1}^2 - q p_{i+1}^2 \nu_{i+1}^1 + e_{i+1}^2(\phi) q_{i+1}^1 - e_{i+1}^1(\phi) q p_{i+1}^2 = 0 \end{aligned}$$

We have

$$\begin{aligned} q_{i+1}^1 q_{i+1}^2 - q^2 p_{i+1}^1 p_{i+1}^2 &= q(\delta^1 p_{i+1}^2 + \delta^2 p_{i+1}^1) + \delta^1 \delta^2 \\ q_{i+1}^2 \nu_{i+1}^1 - q p_{i+1}^1 \nu_{i+1}^2 &= \delta^1 p_{i+1}^2 (\nu - q) + \delta^2 q p_{i+1}^1 + \delta^1 \delta^2 \\ e_{i+1}^1(\phi) q_{i+1}^2 - e_{i+1}^2(\phi) q p_{i+1}^1 &= e(\phi) p_{i+1}^1 \delta^2 \end{aligned}$$

using the fact that $e(\phi) = p_i q_i - \nu_i + 1$, we can show that the intersection point of the two lines (1) and (2) is on the same side of the line (0) than the origin.

EXAMPLE 4.18. (see Figure 24)

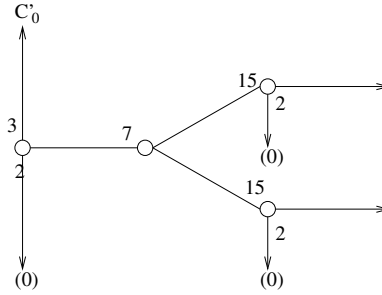

Figure 24.

The three inequalities give a polytope of quasi-adjunction.

$$\begin{aligned} 14(s_1 - 1) + 14(s_2 - 1) + 8 &> 0 \\ 30(s_1 - 1) + 28(s_2 - 1) + 17 &> 0 \\ 28(s_1 - 1) + 30(s_2 - 1) + 17 &> 0 \end{aligned}$$

Then Case I is proved

Case II

We study the case where $r = 3$ and the three germs are connected by a vertex decorated by $(1, 1)$.

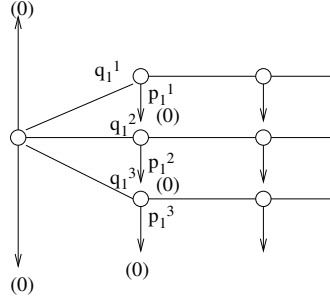

Figure 25.

We compute the log-canonical wall. We have to consider the following inequalities.

$$\begin{aligned} &\prod_1^{r^1} p_l^1 (s_1 - 1) + \prod_1^{r^2} p_l^2 (s_2 - 1) + \prod_1^{r^3} p_l^3 (s_3 - 1) + 2 > 0 \\ &q_1^1 p_1^1 \prod_2^{r^1} p_l^1 (s_1 - 1) + p_1^1 \prod_1^{r^2} p_l^2 (s_2 - 1) + p_1^1 \prod_1^{r^3} p_l^3 (s_3 - 1) + \nu_1^1 > 0 \\ &p_1^2 \prod_1^{r^1} p_l^1 (s_1 - 1) + q_1^2 p_1^2 \prod_2^{r^2} p_l^2 (s_2 - 1) + p_1^2 \prod_1^{r^3} p_l^3 (s_3 - 1) + \nu_1^2 > 0 \\ &p_1^3 \prod_1^{r^1} p_l^1 (s_1 - 1) + p_1^3 \prod_1^{r^2} p_l^2 (s_2 - 1) + q_1^3 p_1^3 \prod_2^{r^3} p_l^3 (s_3 - 1) + \nu_1^3 > 0 \\ &q_i^1 p_i^1 \prod_{i+1}^{r^1} p_l^1 (s_1 - 1) + \prod_1^i p_l^1 \prod_1^{r^2} p_l^2 (s_2 - 1) + \prod_1^i p_l^1 \prod_1^{r^3} p_l^3 (s_3 - 1) + \nu_i^1 > 0, 2 \leq i \leq r^1 \\ &\prod_1^j p_l^2 \prod_1^{r^1} p_l^1 (s_1 - 1) + q_j^2 p_j^2 \prod_{j+1}^{r^2} p_l^2 (s_2 - 1) + \prod_1^j p_l^2 \prod_1^{r^3} p_l^3 (s_3 - 1) + \nu_j^2 > 0, 2 \leq j \leq r^2 \\ &\prod_1^k p_l^3 \prod_1^{r^1} p_l^1 (s_1 - 1) + \prod_1^k p_l^3 \prod_1^{r^2} p_l^2 (s_2 - 1) + q_k^3 p_k^3 \prod_{k+1}^{r^3} p_l^3 (s_3 - 1) + \nu_k^3 > 0, 2 \leq k \leq r^3 \end{aligned}$$

It is easy to check that the three last sets of inequality do not contribute to the log-canonical wall. We show that the four remaining inequalities all contribute to the log-canonical wall. Let

$$\begin{aligned} (0) &\prod_1^{r^1} p_l^1 (s_1 - 1) + \prod_1^{r^2} p_l^2 (s_2 - 1) + \prod_1^{r^3} p_l^3 (s_3 - 1) + 2 = 0 \\ (1) &q_1^1 p_1^1 \prod_2^{r^1} p_l^1 (s_1 - 1) + p_1^1 \prod_1^{r^2} p_l^2 (s_2 - 1) + p_1^1 \prod_1^{r^3} p_l^3 (s_3 - 1) + \nu_1^1 = 0 \\ (2) &p_1^2 \prod_1^{r^1} p_l^1 (s_1 - 1) + q_1^2 p_1^2 \prod_2^{r^2} p_l^2 (s_2 - 1) + p_1^2 \prod_1^{r^3} p_l^3 (s_3 - 1) + \nu_1^2 = 0 \\ (3) &p_1^3 \prod_1^{r^1} p_l^1 (s_1 - 1) + p_1^3 \prod_1^{r^2} p_l^2 (s_2 - 1) + q_1^3 p_1^3 \prod_2^{r^3} p_l^3 (s_3 - 1) + \nu_1^3 = 0 \end{aligned}$$

We consider the intersection of the planes (0), (1), (2) with $\{s_3 = 1\}$. It is easy to verify that the trace of the log-canonical wall is given by (1) and (2) and that the the three lines intersect. Then the first inequality does occur in the log-canonical wall.

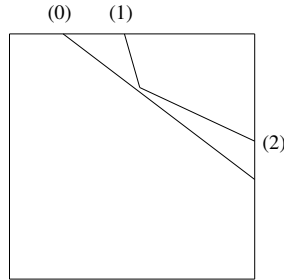

Figure 26.

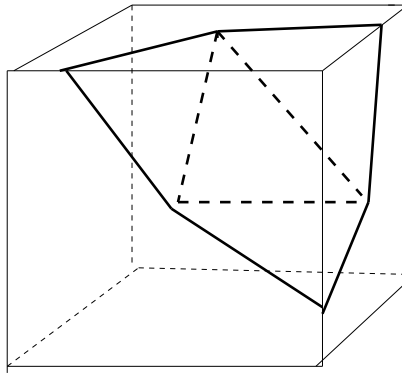

Figure 27.

We have finished the proof of Theorem 4.1 (see Figure 27).

4.3. Computation of the log-canonical wall.

DEFINITION 4.19. *The Newton nest of a Newton tree is the set of vertices v whose set of preceding vertices \mathcal{S}_v is empty or satisfies, for all $v' \in \mathcal{S}_v$ with nearby decorations (q', p') either $p' = 1$ or $q' = 1$.*

REMARK 4.20. *The Newton nest of a Newton tree doesn't depend on the system of coordinates since for all vertex in the Newton tree there exists a system of coordinates such that this vertex is on the Newton polygon. Note that there doesn't*

exist in general a system of coordinates such that all vertices are on the Newton polygon.

EXAMPLE 4.21. (see figure 28)

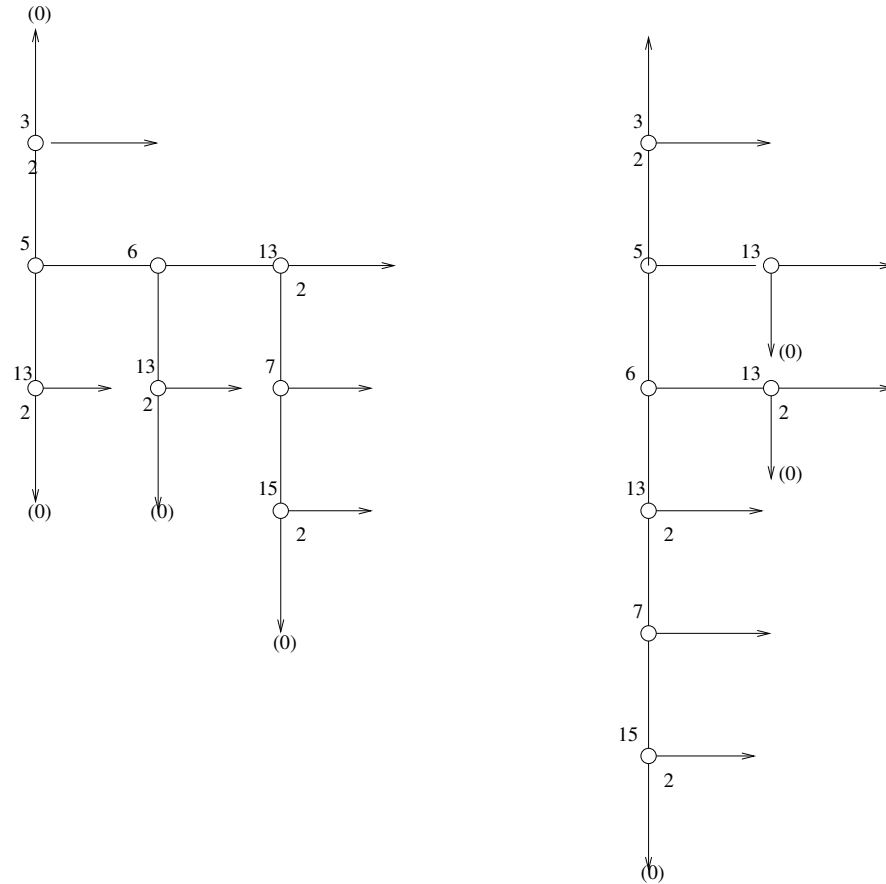

Figure 28.

In this example all vertices of the Newton tree belong to the Newton nest of the Newton tree. On the right hand side of the figure we show the Newton tree in a different system of coordinates.

Theorem 4.22. (1) The log-canonical wall is given by the set of inequalities

$$\sum N_{i,v}(s_i - 1) + \nu_v > 0$$

where v runs through the Newton nest of $f_1 \cdots f_r$.

- (2) For each v in the Newton nest of $f_1 \cdots f_r$ there exists a face of the log canonical wall with equation

$$\sum N_{i,v}(s_i - 1) + \nu_v = 0$$

Corollary 4.23. *The product of $\sum N_{i,v}(s_i - 1) + \nu_v$ where v runs over the Newton nest divides all polynomials in the Bernstein ideal.*

The corollary is a consequence of Theorem 4.22 and [6].

Proof. The log-canonical wall is given by the inequalities

$$\sum N_{i,v}(s_i - 1) + \nu_v > 0$$

where v runs through all the vertices of the Newton tree. We first prove that if v doesn't belong to the Newton nest, then the corresponding inequality is implied by the inequalities with v in the Newton nest. A vertex doesn't belong to the Newton nest if its set of preceding vertices \mathcal{S}_v is not empty and if there exists $v' \in \mathcal{S}_v$ with nearby decorations (q', p') with $p' > 1$ and $q' > 1$. Let v with nearby decorations (q, p) be a vertex not in the Newton nest, $\{v_0, \dots, v_k, v\}$ its set of preceding vertices. Let j be the biggest index such that the nearby decorations of v_j are (q_j, p_j) with $p_j > 1$ and $q_j > 1$.

We have

$$q = q_k p + \delta_1, q_k = q_{k-1} + \delta_2, \dots, q_{j+1} = q_j p_j + \delta_{k-j+1}$$

Then $q = q_j p_j p + \delta_1 + p(\delta_2 + \dots + \delta_{k-j+1}) = q_j p_j p + \Delta$.

$$\nu_v = \nu_{v_k} p + \delta_1, \nu_{v_k} = \nu_{v_{k-1}} + \delta_2, \dots, \nu_{v_{j-1}} = \nu_{v_j} + \delta_{k-j+1}, \nu_v = \nu_{v_j} p + \Delta$$

We have

$$\nu_v q_j p_j - \nu_{v_j} q = \Delta(p_j q_j - \nu_j)$$

Consider $1 \leq i \leq r$. We have 3 cases: The intersection of the path between v_j and the arrow representing f_i and the path between v_j and v is

- (1) empty
 - (2) is the path between v_j and v
 - (3) is a non empty part of the path between v_j and v
- (1) In this case, we have $N_{i,v} = p N_{i,v_j}$, $\nu_v > \nu_{v_j} p$. Then $\frac{\nu_v}{N_{i,v}} > \frac{\nu_{v_j}}{N_{i,v_j}}$.
 - (2) In this case, we have $N_{i,v_j} q = p_j q_j N_v$ and since $p_j > 1$ and $q_j > 1$, $p_j q_j - \nu_j > 0$ we deduce that $\frac{\nu_v}{N_{i,v}} > \frac{\nu_{v_j}}{N_{i,v_j}}$.

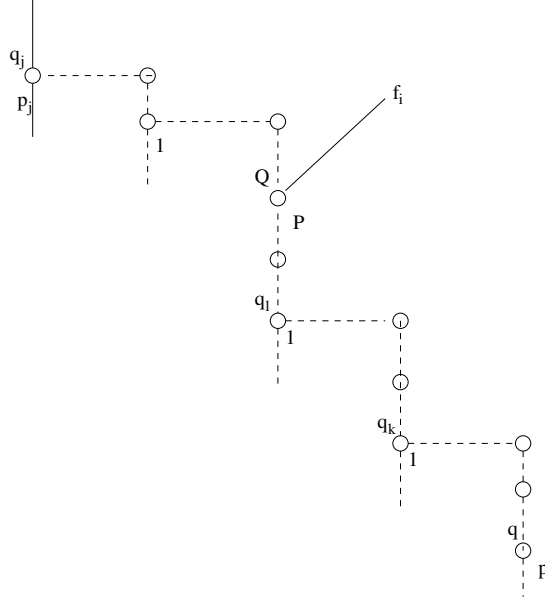

Figure 29.

- (3) We denote by V the vertex where f_i separates from the path between v_j and v . We assume that V has nearby decorations (Q, P) . We denote by v_{l-1} the preceding vertex of V . We have $N_{i,v_j} = p_j q_j P N$ and $N_{i,v} = p Q N$.

We have $qP - Qp > 0$, then $p_j q_j N_{i,v} < q N_{i,v_j}$. Finally $\frac{\nu_v}{N_{i,v}} > \frac{\nu_{v_j}}{N_{i,v_j}}$. Then we have proved that the inequality for v is implied by the inequality for v_j .

Now we have to prove that indeed all inequalities for v in the Newton nest occur in the log-canonical wall. We use induction on r . The trace of the log-canonical wall on the hyperplane $\{s_1 = 1\}$ is the log-canonical wall of f_2, \dots, f_r .

If $r = 1$, the Newton nest consists in one vertex, the first one. Then the result is proved in this case. Assume that it is true for $r - 1$. Consider f_1, \dots, f_r . The Newton nest of $f_1 \cdots f_r$ is the union of the Newton nests of $f_1 \cdots f_{i-1} f_{i+1} \cdots f_r$ for all i except in the exceptional cases. But we already proved that in these cases the log canonical wall is given by the Newton nest. \square

EXAMPLE 4.24.

$$f_1 = y^2 - x^5, \quad f_2 = x^4 - y^3$$

The inequalities to be satisfied are

$$10s_1 + 8s_2 > 11 - (5a + 2b) \quad (8s_1 + 12s_2 > 13 - (4a + 3b))$$

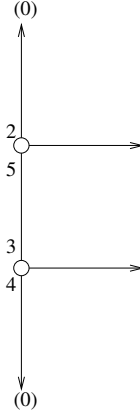

Figure 30.

for all $(a, b) \in \mathbb{N}^2$.

There are three pairs of half faces of quasi-adjunction given as the boundary of the sets

$$10s_1 + 8s_2 \geq 11, \quad 8s_1 + 12s_2 \geq 13$$

$$10s_1 + 8s_2 \geq 9, \quad 8s_1 + 12s_2 \geq 10$$

$$10s_1 + 8s_2 \geq 7, \quad 8s_1 + 12s_2 \geq 7$$

The other faces of quasi-adjunction are:

$$10s_1 + 8s_2 = 5, \quad 10s_1 + 8s_2 = 3, \quad 10s_1 + 8s_2 = 1$$

$$8s_1 + 12s_2 = 9, \quad 8s_1 + 12s_2 = 6, \quad 8s_1 + 12s_2 = 5, \quad 8s_1 + 12s_2 = 3, \quad 8s_1 + 12s_2 = 2, \quad 8s_1 + 12s_2 = 1$$

Any polynomial in the Bernstein ideal \mathcal{B}_{f_1, f_2} is divisible by

$$\prod_{i=3}^{i=8} (10s_1 + 8s_2 + 2i + 1)(8s_1 + 12s_2 + 7)(8s_1 + 12s_2 + 10)(8s_1 + 12s_2 + 11)(8s_1 + 12s_2 + 13)$$

$$(8s_1 + 12s_2 + 14)(8s_1 + 12s_2 + 15)(8s_1 + 12s_2 + 17)(8s_1 + 12s_2 + 18)(8s_1 + 12s_2 + 19)$$

EXAMPLE 4.25. The following example is degenerate.

$$f_1 = (x^3 - y^4), \quad f_2 = ((x^2 - y^3)^2 + x^3y^2)$$

The log canonical wall is given by the two inequalities:

$$12s_1 + 8s_2 > 15 \quad 16s_1 + 12s_2 > 21$$

There are two interesting features to notice in this example.

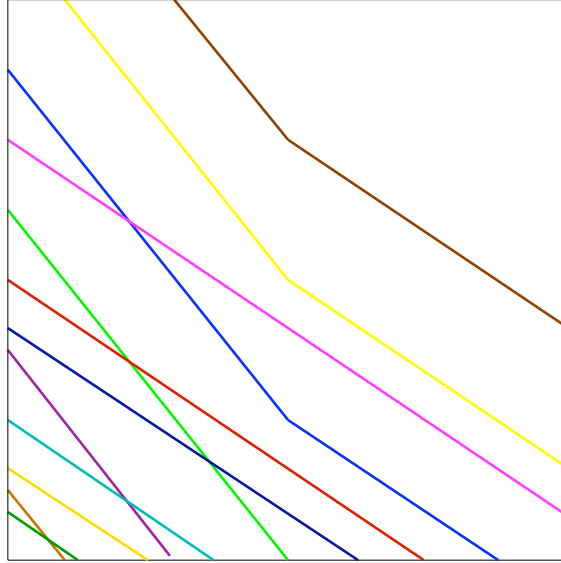

Figure 31.

First we have a polytope of quasi-adjunction given by the three inequalities

$$12s_1 + 8s_2 > 13 \quad 26s_1 + 16s_2 > 27 \quad 16s_1 + 12s_2 > 18$$

Second, we have a polytope of quasi-adjunction given by

$$16s_1 + 12s_2 > 17 \quad 26s_1 + 16s_2 > 25$$

which shows that the set of vertices given a polytope of quasi-adjunction is not always connected in the Newton tree.

5. Distribution of constant and polytopes of quasi-adjunction

Shokurov made the conjecture and prove it in dimension two, that the set of log canonical thresholds satisfy the ACC condition. This means that there are no strictly increasing sequences of log canonical thresholds. More over it is proven also that the set of limits of strictly decreasing sequences of log canonical thresholds is the set $\{0, 1/n\}, n \in \mathbb{N}$.

One can ask the question for other constant of quasi-adjunction. We can answer this question for the constants of quasi-adjunction associated to $\phi = x^\alpha y^\beta$.

Let f be any germ in $\mathbb{C}[[x, y]]$. Consider its Newton tree, and denote by \mathcal{V} the set of vertices of its Newton tree. Then the constant of quasi-adjunction of f

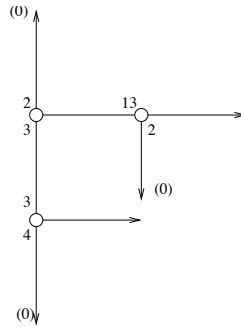

Figure 32.

associated to ϕ is

$$\min_{v \in \mathcal{V}} \frac{\nu_v + e_v(\phi)}{N_v}$$

If $\phi = 1$, i.e. $\alpha = \beta = 0$, it is the log canonical threshold.

First, we will give an example of a sequence of f 's and ϕ for which the sequence of constants of quasi-adjunction is increasing.

EXAMPLE 5.1. Consider a germ with the following Newton tree.

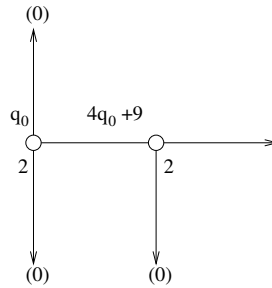

Figure 33.

Let $\phi = y^2$. Then the associated constant of quasi-adjunction is

$$\min\left\{\frac{2 + 3q_0}{4q_0}, \frac{13 + 6q_0}{18 + 8q_0}\right\} = \frac{13 + 6q_0}{18 + 8q_0}$$

When q_0 goes to infinity $\frac{13+6q_0}{18+8q_0}$ is an increasing sequence which converges to $\frac{3}{4}$.

In [19], it is proven that the Ascending Chain Condition holds for LCT-polytopes, that is that all increasing chain of LCT-polytopes is eventually stationary. We give

an example to show that it is no more true for the polytopes of quasi-adjunction associated to a $\phi \neq 1$.

EXAMPLE 5.2. *We consider the germ with two irreducible components whose Newton tree is the following.*

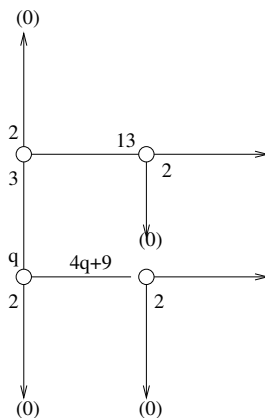

Figure 34.

We take $\phi = y^2$. we have the four inequalities

$$\begin{aligned}
 (1) \quad & 12(s_1 - 1) + 8(s_2 - 1) > -9 \\
 (2) \quad & 26(s_1 - 1) + 16(s_2 - 1) > -19 \\
 (3) \quad & 8(s_1 - 1) + 4q(s_2 - 1) > -(2 + 3q) \\
 (4) \quad & 16(s_1 - 1) + 2(4q + 9)(s_2 - 1) > -(13 + 6q)
 \end{aligned}$$

The polytope of quasi-adjunction is given by the three lines

$$\begin{aligned}
 (1) \quad & 12(s_1 - 1) + 8(s_2 - 1) = -9 \\
 (2) \quad & 26(s_1 - 1) + 16(s_2 - 1) = -19 \\
 (4) \quad & 16(s_1 - 1) + 2(4q + 9)(s_2 - 1) = -(13 + 6q)
 \end{aligned}$$

When q goes to infinity, the two first lines are fixed and the third one tends to the line $s_2 = 1/4$. Then we have a non stationary increasing sequence of polytopes.

Proposition 5.3. *Consider a germ $f \in \mathbb{C}[[x, y]]$. Assume that the nearby decorations of the vertex connected by an edge to the upper arrow are (q_0, p_0) and that q_0 goes to infinity. Then the constant of quasi-adjunction associated to $\phi = x^\alpha y^\beta$ tends to $\frac{\beta+1}{n}$, where n is the multiplicity of f .*

REMARK 5.4. *We retrieve the result for the log canonical threshold that is when $\alpha = 0, \beta = 0$ the limit is $\frac{1}{n}$ proven by [13].*

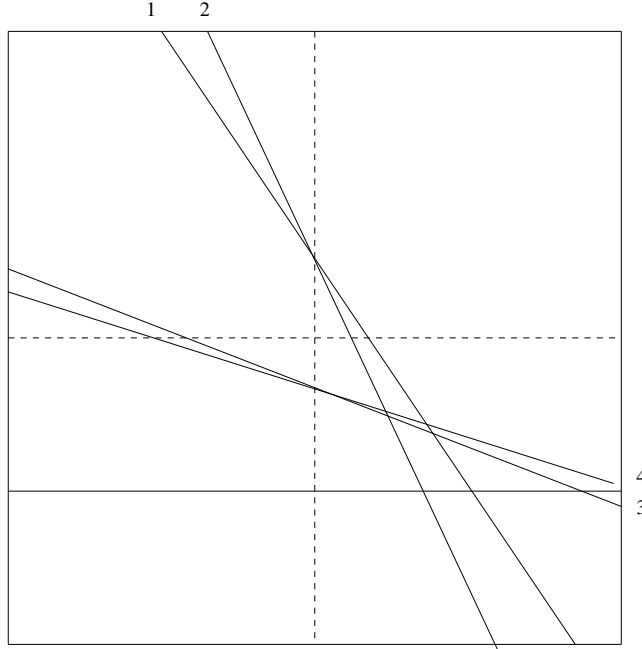

Figure 35.

Proof. Let \mathcal{V} be the set of vertices of the Newton tree. We have to consider

$$\min_{\mathcal{V}} \frac{\nu_v + e_v(\phi)}{N_v}$$

We will show that for all $v \in \mathcal{V}$, $\frac{\nu_v + e_v(\phi)}{N_v}$ tends to $\frac{\beta}{n}$ when q_0 goes to infinity.

We prove the result by induction on the number of successive vertical lines of the Newton tree.

Consider a vertex on the first vertical line.

For each vertex v_i of the first vertical line, we define by n_i the sum of the products of the numbers adjacent to the paths containing the horizontal edges issued from v_i , between v_i and the arrows. We have

$$n = \sum_i p_j n_j$$

We have

$$\nu_i + e_i(\phi) = (\alpha + 1)p_i + (\beta + 1)q_i$$

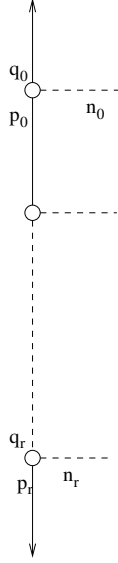

Figure 36.

and

$$N_i = q_i \sum_i^r p_j n_j + p_i \sum_1^{i-1} q_j n_j$$

We denote by δ_i the edge determinant between v_{i-1} and v_i . We can write

$$q_j = q_0 p_j / p_0 + f_j(\delta, p)$$

where f_j depends only on the δ 's and p 's. We have $q_1 p_0 - q_0 p_1 = \delta_1$. Then $q_1 = q_0 p_1 / p_0 + \delta_1 / p_0$. Assume $q_j = q_0 p_j / p_0 + f_j(\delta, p)$. We have $q_{j+1} p_j - q_j p_{j+1} = \delta_{j+1}$, then $q_{j+1} = q_0 p_{j+1} / p_0 + f_j(\delta, p) p_{j+1} / p_j + \delta_{j+1} / p_j$, then $q_{j+1} = q_0 p_{j+1} / p_0 + f_{j+1}(\delta, p)$. We can write

$$N_i = q_0 p_i / p_0 \sum_i^r p_j n_j + p_i \sum_1^{i-1} (q_0 p_j / p_0 + f_j(\delta, p)) n_j$$

$$N_i = q_0 p_i / p_0 n + p_i \sum_1^{i-1} f_j(\delta, p) n_j$$

$$\nu_i + e_i(\phi) = (\alpha + 1) p_i + (\beta + 1) (q_0 p_i / p_0 + f_i(\delta, p))$$

Then the assertion is proved for every vertex on the first vertical line.

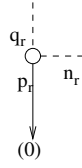
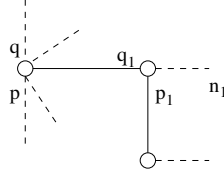

Figure 37.

We assume now that the assertion is true for all the vertices of the k -th vertical line.

We consider a vertex v on the k -th vertical line and we assume that for this vertex

$$\lim_{q_0 \rightarrow \infty} \frac{\nu + e(\phi)}{N} = \frac{\beta + 1}{n}$$

Consider a vertex v_i on a $k + 1$ -th vertical line issued from v . We have

$$\nu_i + e_i(\phi) = \nu p_i + \delta'_i + e(\phi) p_i$$

where $\delta'_i = q_i - q p p_i$. We can write

$$N = N' + p q \sum_1^r p_j n_j$$

Then

$$N_i = N' p_i + p_i \sum_1^{i-1} q_j n_j + q_i \sum_i^r p_j n_j$$

$$N_i = N' p_i + p_i \sum_1^{i-1} (q p p_j + \delta'_j) n_j + (q p p_i + \delta'_i) \sum_i^r p_j n_j$$

$$N_i = p_i N + p_i \sum_1^{i-1} \delta'_j n_j + \delta'_i \sum_i^r p_j n_j$$

Then

$$\frac{\nu_i + e_i(\phi)}{N_i} = \frac{(\nu + e(\phi))p_i + \delta'_i}{p_i N + p_i \sum_1^{i-1} \delta'_j n_j + \delta'_i \sum_i^r p_j n_j}$$

Then the result is proved. \square

References

- [1] A.ADEM, J.LEIDA, Y. RUAN, Orbifolds and stringy topology. Cambridge Tracts in Mathematics, 171. Cambridge University Press, Cambridge, 2007.
- [2] E. ARTAL BARTOLO, P. CASSOU-NOGUÈS, I. LUENGO, A. MELLE HERNÁNDEZ, Quasi-ordinary power series and their zeta functions, Mem. Amer. Math. Soc. 178 (2005), no. 841.
- [3] E. ARTAL BARTOLO, P. CASSOU-NOGUÈS, I. LUENGO, A. MELLE HERNÁNDEZ, On ν -quasi-ordinary power series: factorization, Newton trees and resultants. Topology of algebraic varieties and singularities, 321343, Contemp. Math., 538, Amer. Math. Soc., Providence, RI, 2011
- [4] N.A'CAMPO, M.OKA, Geometry of plane curves via Tschirnhausen resolution tower. Osaka J. Math. 33 (1996), no. 4, 1003-1033.
- [5] P. CASSOU-NOGUÈS, Newton trees at infinity of algebraic curves. Affine algebraic geometry, 119, CRM Proc. Lecture Notes, 54, Amer. Math. Soc., Providence, RI, 2011.
- [6] P. CASSOU-NOGUÈS, A. LIBGOBER, Multivariable Hodge theoretical invariants of germs of plane curves. Journal of Knot theory and its ramifications, vol. 20, n 6, (2011), 787-805.
- [7] P. CASSOU-NOGUÈS, W. VEYS, Newton trees for ideals in two variables and applications. ArXiv 1201.0467.
- [8] P. CASSOU-NOGUÈS, W.VEYS, In preparation.
- [9] D. EISENBUD, W. NEUMANN, Three dimensional link theory and invariants of plane curve singularities, Annals of Mathematic studies, 110, Princeton University press, Princeton, NJ, (1985).
- [10] W.FULTON, Introduction to toric varieties. Annals of Mathematics Studies, 131. The William H. Roever Lectures in Geometry. Princeton University Press, Princeton, NJ, 1993.
- [11] P.D GONZALEZ PÉREZ, Toric embedded resolutions of quasi-ordinary hypersurface singularities. Ann. Inst. Fourier (Grenoble) 53 (2003), no. 6, 18191881.
- [12] A.GYOJA, Bernstein-Sato's polynomial for several analytic functions. J. Math. Kyoto Univ. 33 (1993), no. 2, 399-411.
- [13] J.KOLLAR, Singularities of pairs. Algebraic geometry—Santa Cruz 1995, 221-287, Proc. Sympos. Pure Math., 62, Part 1, Amer. Math. Soc., Providence, RI, 1997.
- [14] Y.KAWAMATA, On algebraic fiber spaces. Contemporary trends in algebraic geometry and algebraic topology (Tianjin, 2000), 135154, Nankai Tracts Math., 5, World Sci. Publ., River Edge, NJ, 2002.

- [15] G.KEMPF, F.KNUDSEN, D.MUMFORD, B.SAINT-DONAT, Toroidal embeddings. I. Lecture Notes in Mathematics, Vol. 339. Springer-Verlag, Berlin-New York, 1973.
- [16] D.T.LÊ, M.OKA, On resolution complexity of plane curves. Kodai Math.J. 18 (1995), 1-36.
- [17] A.LIBGOBER, Characteristic varieties of algebraic curves. Applications of algebraic geometry to coding theory, physics and computation (Eilat, 2001), 215–254, NATO Sci. Ser. II Math. Phys. Chem., 36, Kluwer Acad. Publ., Dordrecht, 2001.
- [18] A.LIBGOBER, Hodge decomposition of Alexander invariants. Manuscripta Math. 107 (2002), no. 2, 251–269.
- [19] A. LIBGOBER, M. MUSTATA, Sequences of LCT-polytopes. Math. Res. Lett. 18 (2011), no. 4, 733746.
- [20] F.LOESER, M.VAQUIE, Le polynôme d’Alexander d’une courbe plane projective. Topology 29 (1990), no. 2, 163173
- [21] A. NEMETHI, W. VEYS, Generalized monodromy conjecture in dimension two. ArXiv 1112.1230.
- [22] M. OKA, Geometry of plane curves via toroidal resolution. Algebraic geometry and Singularities, (La Rabida, 1991) 95-121, Prog. Math, 134, Birkhauser, basel, 1996.
- [23] C.SABBAH, Proximité évanescence. I. La structure polaire d’un D -module. Compositio Math. 62 (1987), no. 3, 283–328, Proximité évanescence. II. Equations fonctionnelles pour plusieurs fonctions analytiques. Compositio Math. 64 (1987), no. 2, 213–241.
- [24] M.SAITO, Exponents of an irreducible plane singularity. ArXiv 0009133.
- [25] B.TOTARO, The ACC conjecture for log canonical thresholds (after de Fernex, Ein, Mustata, Kollar), Asterisque (2011), no. 339, Exp. No. 1025, ix, 371385, Séminaire Bourbaki. Vol. 2009/2010. Exposé 10121026.
- [26] C.T.C.WALL, Singular points of plane curves. London Mathematical Society Student Texts, 63. Cambridge University Press, Cambridge, 2004.
- [27] J.WŁODARCZYK, Toroidal varieties and the weak factorization theorem. Invent. Math. 154 (2003), no. 2, 223331.
- [28] W. VEYS, Zeta functions for curves and log canonical models. Proc. London Math. Soc. (3) 74 (1997), no. 2, 360378.

Pierrette Cassou-Noguès, Institut de mathématiques de Bordeaux,
 Université Bordeaux I,
 351, Cours de la Libération, 33405, Talence Cedex, France.
 E-mail: Pierrette.Cassou-nogues@math.u-bordeaux1.fr

Anatoly Libgober, Department of Mathematics, Statistics and Computer Sciences,
 University of Illinois at Chicago, 851 S.Morgan, Chicago, Illinois, 60607
 E-mail: libgober@uic.edu